

APPENDIX 112

UNITIZATION PROCEDURES FOR BOXED AMMUNITION AND COMPONENTS ON 4-WAY ENTRY PALLETS

SIMULATOR, FLASH, PACKED 30 PER WOODEN BOX,
UNITIZED 18 BOXES PER 35" X 45 $\frac{1}{2}$ " PALLET;
APPROX BOX SIZE 19 $\frac{5}{8}$ " L X 14 $\frac{7}{16}$ " W X 10 $\frac{31}{32}$ " H

PALLET UNIT DATA						
ITEMS INCLUDED		HAZARD CLASSIFICATION ^①				WEIGHT (LBS)
NSN	DODIC	DOT CLASS	CG CLASS	QD CLASS	COMP GROUP	
1370- 00-028-5112	L596	B	IX-A	1.3	G	1,060
00-935-1969	L596	B	IX-A	1.3	G	1,060

REVISION

REVISION NO. 1, DATED OCTOBER 1984, CONSISTS OF:

1. CHANGING BOX DIMENSIONS.
2. UPDATING DRAWING FORMAT TO CONFORM WITH NO. 1 ABOVE.

NOTICE: THIS APPENDIX CANNOT STAND ALONE BUT MUST BE
USED IN CONJUNCTION WITH THE BASIC UNITIZATION
PROCEDURES DRAWING 19-48-4116-20PA1002.

① HAZARD CLASSIFICATION DATA CONTAINED IN THE ABOVE CHART IS FOR GUIDANCE AND INFORMATIONAL PURPOSES ONLY. VERIFICATION OF THE SPECIFIED DATA SHOULD BE MADE BY CONSULTING THE MOST RECENT JOINT HAZARD CLASSIFICATION SYSTEM LISTING OR OTHER APPROVED LISTING(S).

DO NOT SCALE

REVISIONS				PROJ ENG	PROJ SGT
1	OCT 84	NRE 10	[Signature]	[Signature]	[Signature]
				CHECKED RSW	LOS ENGINE OFFICE [Signature]
				APPROVED, U. S. ARMY ARMAMENT MATERIAL READINESS COMMAND	
				[Signature]	[Signature]
				DR SAR - MAD	DR SAR - TMA
				APPROVED BY ORDER OF COMMANDING GENERAL, U. S. ARMY MATERIAL DEVELOPMENT AND READINESS COMMAND (DARCOM)	
				[Signature] [Signature] DARCOM AMMO CENTER	
U. S. ARMY DARCOM DRAWING					
DECEMBER 1977					
CLASS	DIVISION	DRAWING	FILE		
19	48	4116/112	20PA 1002		

GENERAL NOTES

- A. THIS APPENDIX CANNOT STAND ALONE BUT MUST BE USED IN CONJUNCTION WITH THE BASIC UNITIZATION PROCEDURES DRAWING 19-48-4116-20PA1002, TO PRODUCE AN APPROVED UNIT LOAD, ALL PERTINENT PROCEDURES, SPECIFICATIONS AND CRITERIA SET FORTH WITHIN THE BASIC DRAWING WILL APPLY TO THE PROCEDURES DELINEATED IN THIS APPENDIX. ANY EXCEPTIONS TO THE BASIC PROCEDURES ARE SPECIFIED IN THIS APPENDIX.
- B. DIMENSIONS, CUBE AND WEIGHT OF A PALLET UNIT WILL VARY SLIGHTLY DEPENDING UPON THE ACTUAL DIMENSIONS OF THE BOXES AND THE WEIGHT OF THE SPECIFIC ITEM BEING UNITIZED.
- C. THE LOAD STRAPS MAY BE THREADED THROUGH THE STRAP SLOT OF A PALLET OR PRE-POSITIONED ON THE PALLET DECK PRIOR TO PLACING BOXES ON THE PALLET. LOAD STRAPS MUST BE TENSIONED AND SEALED PRIOR TO APPLICATION OF TIEDOWN STRAPS.
- D. INSTALL EACH TIEDOWN STRAP TO PASS UNDER THE TOP DECK BOARDS OF THE PALLET AND TO BE LOCATED AS SHOWN. TIEDOWN STRAPS WILL NOT BE APPLIED UNTIL THE LOAD STRAPS HAVE BEEN TENSIONED AND SEALED.
- E. THE FOLLOWING DARCOM DRAWINGS ARE APPLICABLE FOR OUTLOADING AND STORAGE OF THE ITEMS COVERED BY THIS APPENDIX.

CARLOADING -----	DRAWING 19-48-4115-5PA1002
TRUCKLOADING -----	DRAWING 19-48-4117-11PA1003
STORAGE -----	DRAWING 19-48-4118-1-2-3-4-14-22PA1002
- F. FOR METHOD OF SECURING A STRAP CUTTER TO THE PALLET UNIT, SEE DARCOM DRAWING 19-48-4127-20P1000.
- G. IF ITEMS COVERED HEREIN ARE UNITIZED PRIOR TO ISSUANCE OF THIS APPENDIX, THE BOXES NEED NOT BE REUNITIZED SOLELY TO CONFORM TO THIS APPENDIX.
- H. THE UNITIZATION PROCEDURES DEPICTED HEREIN MAY ALSO BE USED FOR UNITIZING FLASH SIMULATORS WHEN IDENTIFIED BY DIFFERENT NATIONAL STOCK NUMBERS (NSN) THAN WHAT IS SHOWN ON THE TITLE PAGE, PROVIDED THE BOX PACK DOES NOT VARY FROM WHAT IS DELINEATED HEREIN. THE EXPLOSIVE CLASSIFICATION OF OTHER ITEMS MAY BE DIFFERENT THAN WHAT IS SHOWN.
- J. THE 39-1/4" LENGTH DIMENSION IS AN EXCEPTION TO THE BASIC PROCEDURES, HOWEVER, THIS EXCEPTION IS NECESSARY FOR THE AMMUNITION PACK COVERED BY THIS APPENDIX, TO MOST EFFECTIVELY GET AN ACCEPTABLE, COMPACT, AND SOUND PALLET UNIT.

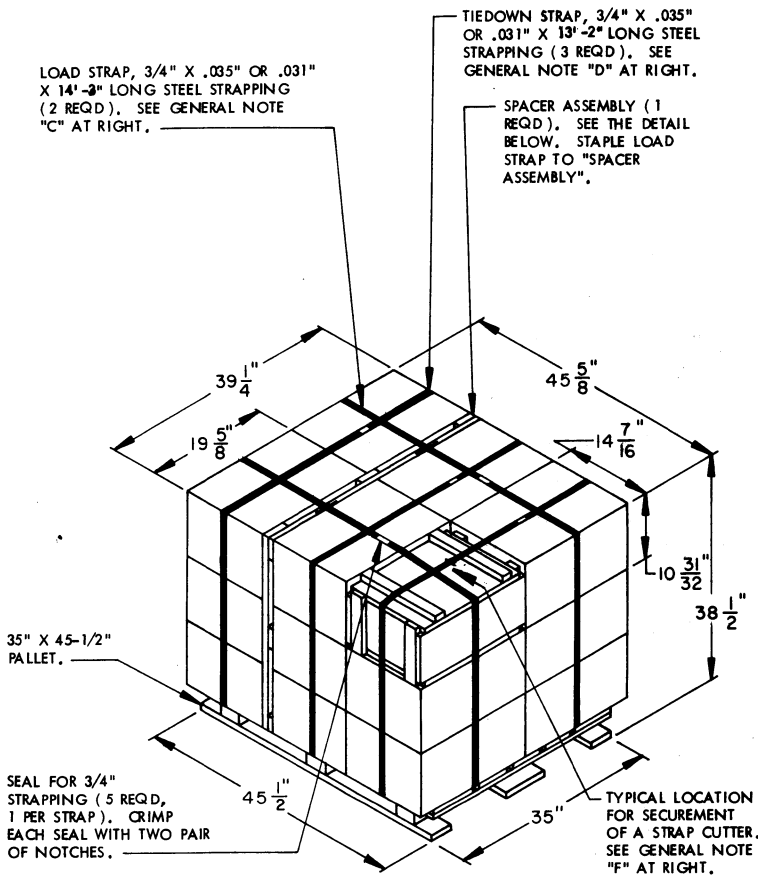

PALLET UNIT

SEE GENERAL NOTE "B" AT RIGHT.

18 BOXES OF FLASH SIMULATORS (30 PER BOX) @ 54 LBS -----	972 LBS (APPROX)
DUNNAGE -----	23 LBS
PALLET -----	65 LBS

TOTAL WEIGHT -----	1,060 LBS (APPROX)
CUBE -----	39.9 CU FT (APPROX)

BILL OF MATERIAL

LUMBER	LINEAR FEET	BOARD FEET
1" X 4"	9.81	3.27
2" X 4"	8.06	5.38
NAILS	NO. REQD	POUNDS
6d (2")	18	0.11

PALLET, 35" X 45-1/2" -----	1 REQD -----	65 LBS
STEEL STRAPPING, 3/4" -----	68.00' REQD -----	4.86 LBS
SEAL FOR 3/4" STRAPPING -----	5 REQD -----	NIL
STAPLE -----	2 REQD -----	NIL

