

APPENDIX 110L

UNITIZATION PROCEDURES FOR BOXED AMMUNITION AND COMPONENTS ON 4-WAY ENTRY PALLET

**FLARE, AIRCRAFT, PACKED TWO PER WOODEN
BOX, UNITIZED 18 BOXES PER 40" X 48" PALLET;
APPROX BOX SIZE 43" L X 16" W X 8" H**

**NOTICE: THIS APPENDIX CANNOT STAND ALONE BUT MUST BE USED IN CONJUNCTION WITH
THE BASIC UNITIZATION PROCEDURES DRAWING 19-48-4116-20PA1002.**

DISTRIBUTION STATEMENT A:

**APPROVED FOR PUBLIC RELEASE;
DISTRIBUTION IS UNLIMITED.**

U.S. ARMY MATERIEL COMMAND DRAWING

| | | | | | | | | |
|---|---|-------|-----------------------|--|-------|----------|---------------|----------|
| APPROVED, U.S. ARMY OPERATIONS SUPPORT COMMAND <i>David A. Pistoril</i> AMSTA-AR-WEP-RP | ENGINEER | BASIC | LAURA FIEFFER | DO NOT SCALE | | | | |
| | | REV. | | WEBSITE: HTTP://WWW.DAC.ARMY.MIL | | | | |
| APPROVED BY ORDER OF COMMANDING GENERAL, U.S. ARMY MATERIEL COMMAND <i>Philip W. ...</i> AMSOS-TM | TECHNICIAN | BASIC | | JANUARY 2002 | | | | |
| | | REV. | | | | | | |
| APPROVED BY ORDER OF COMMANDING GENERAL, U.S. ARMY MATERIEL COMMAND <i>J. Q. ...</i> U.S. ARMY DEFENSE AMMUNITION CENTER | DRAFTSMAN | BASIC | | | | | | |
| | | REV. | | | | | | |
| | TRANSPORTATION ENGINEERING DIVISION | | <i>Philip W. ...</i> | | | | | |
| | VALIDATION ENGINEERING DIVISION | | <i>Greg ...</i> | TESTED | CLASS | DIVISION | DRAWING | FILE |
| | ENGINEERING DIRECTORATE | | <i>William R. ...</i> | | 19 | 48 | 4116/ 110L | 20PA1002 |

| PALLET UNIT DATA | | | | |
|------------------|-------|---------------------------|-----------------------|-------------------|
| ITEMS INCLUDED | | HAZARD CLASS AND DIVISION | ● COMPATIBILITY GROUP | APPROX WEIGHT LBS |
| NSN | DODIC | | | |
| 1370- | | | | |
| 00-292-8411 | L411 | 1.3 | G | 1,726 |
| 00-351-0222 | L411 | 1.3 | G | 1,726 |
| 01-083-0321 | L431 | ———— INERT ———— | ———— | 1,726 |
| 00-500-6878 | L432 | ———— INERT ———— | ———— | 1,726 |
| 01-083-0323 | L440 | 1.3 | G | 1,726 |
| 00-104-5614 | L660 | 1.3 | G | 1,726 |
| 00-135-1590 | LY65 | 1.3 | G | 1,726 |
| 00-195-2668 | UNAS | ———— INERT ———— | ———— | 1,726 |

● HAZARD CLASSIFICATION DATA CONTAINED IN THE ABOVE CHART IS FOR GUIDANCE AND INFORMATIONAL PURPOSES ONLY. VERIFICATION OF THE SPECIFIED DATA SHOULD BE MADE BY CONSULTING THE MOST RECENT JOINT HAZARD CLASSIFICATION SYSTEM LISTING OR OTHER APPROVED LISTING(S).

GENERAL NOTES

SEAL FOR 3/4" STRAPPING
(5 REQD, 1 PER STRAP).
CRIMP EACH SEAL WITH
TWO PAIR OF NOTCHES.

LOAD STRAP, 3/4" X .035" OR .031" X
17'-1" LONG STEEL STRAPPING (2 REQD).
SEE GENERAL NOTE "C" AT RIGHT.

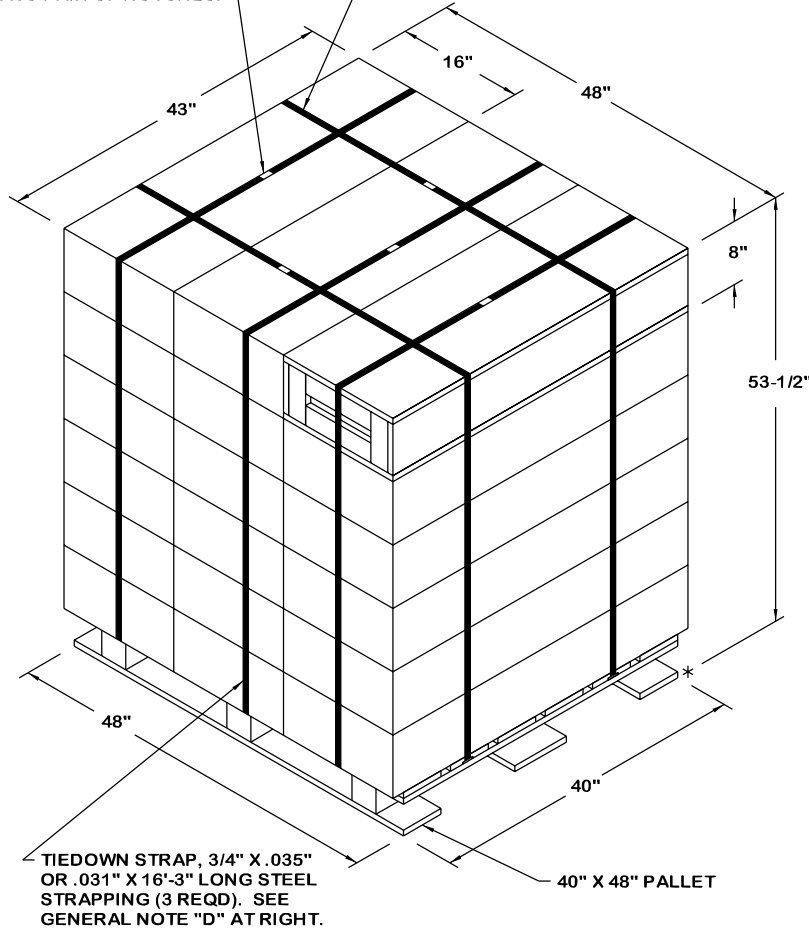

TIEDOWN STRAP, 3/4" X .035"
OR .031" X 16'-3" LONG STEEL
STRAPPING (3 REQD). SEE
GENERAL NOTE "D" AT RIGHT.

40" X 48" PALLET

PALLET UNIT

SEE GENERAL NOTE "B" AT RIGHT.

18 BOXES OF AIRCRAFT FLARES (2 PER BOX) @ 91 LBS -- 1,638 LBS (APPROX)
DUNNAGE ----- 8 LBS
PALLET ----- 80 LBS

TOTAL WEIGHT ----- 1,726 LBS (APPROX)
CUBE ----- 63.9 CU FT (APPROX)

| BILL OF MATERIAL | | | |
|-------------------------|-------------|----------|--|
| PALLET, 40" X 48" | 1 REQD | 80 LBS | |
| STEEL STRAPPING, 3/4" | 82.92' REQD | 7.41 LBS | |
| SEAL FOR 3/4" STRAPPING | 5 REQD | NIL | |

- A. THIS APPENDIX CANNOT STAND ALONE BUT MUST BE USED IN CONJUNCTION WITH THE BASIC UNITIZATION PROCEDURES DRAWING 19-48-4116-20PA1002. TO PRODUCE AN APPROVED UNIT LOAD, ALL PERTINENT PROCEDURES, SPECIFICATIONS AND CRITERIA SET FORTH WITHIN THE BASIC DRAWING WILL APPLY TO THE PROCEDURES DELINEATED IN THIS APPENDIX. ANY EXCEPTIONS TO THE BASIC PROCEDURES ARE SPECIFIED IN THIS APPENDIX.
- B. DIMENSIONS, CUBE AND WEIGHT OF A PALLET UNIT WILL VARY SLIGHTLY DEPENDING UPON THE ACTUAL DIMENSIONS OF THE BOXES AND THE WEIGHT OF THE SPECIFIC ITEM BEING UNITIZED.
- C. THE LOAD STRAPS MAY BE THREADED THROUGH THE STRAP SLOTS OF A PALLET OR PRE-POSITIONED ON THE PALLET DECK PRIOR TO PLACING THE BOXES ON THE PALLET. LOAD STRAPS MUST BE TENSIONED AND SEALED PRIOR TO APPLICATION OF TIEDOWN STRAPS.
- D. INSTALL EACH TIEDOWN STRAP TO PASS UNDER THE TOP DECK BOARDS OF THE PALLET AND TO BE LOCATED AS SHOWN. TIEDOWN STRAPS WILL NOT BE APPLIED UNTIL THE LOAD STRAPS HAVE BEEN TENSIONED AND SEALED.
- E. THE FOLLOWING AMC DRAWINGS ARE APPLICABLE FOR OUTLOADING AND STORAGE OF THE ITEMS COVERED BY THIS APPENDIX.
 - CARLOADING - - - - 19-48-4115-5PA1002
 - TRUCKLOADING - - - - 19-48-4117-11PA1003
 - STORAGE - - - - - 19-48-4118-1-2-3-4-14-22PA1002
 - END OPENING ISO CONTAINER - - - - - 19-48-4153-15PA1002
 - MILVAN - - - - - 19-48-4166-15PA1003
 - SIDE OPENING ISO CONTAINER - - - - - 19-48-4267-15PA1009
- F. IF ITEMS COVERED HEREIN ARE UNITIZED PRIOR TO ISSUANCE OF THIS APPENDIX, THE BOXES NEED NOT BE REUNITIZED SOLELY TO CONFORM TO THIS APPENDIX.
- G. THE UNITIZATION PROCEDURES DEPICTED HEREIN MAY ALSO BE USED FOR UNITIZING AIRCRAFT FLARES WHEN IDENTIFIED BY DIFFERENT NATIONAL STOCK NUMBERS (NSN) THAN WHAT IS SHOWN ON PAGE 2, PROVIDED THE BOX PACK DOES NOT VARY FROM WHAT IS DELINEATED HEREIN. THE EXPLOSIVE CLASSIFICATION OF OTHER ITEMS MAY BE DIFFERENT THAN WHAT IS SHOWN.
- H. THE STYLE 1 PALLET DELINEATED IN THE DETAIL AT LEFT NEED NOT HAVE CHAMFERS OR STRAP SLOTS AS SPECIFIED WITHIN MILITARY SPECIFICATION MIL-P-15011 WHEN USED FOR THE UNITIZATION OF ITEMS COVERED BY THIS APPENDIX.
- J. WHEN THE UNIT LOAD DEPICTED AT LEFT IS TO BE USED FOR UNITIZING MARINE CORPS AMMUNITION, TWO LAYERS OF BOXES MUST BE OMITTED, TIEDOWN STRAP LENGTHS MUST BE DECREASED TO 13'-7", AND LOAD STRAP LENGTHS MUST BE DECREASED TO 14'-5". THIS WILL RESULT IN AN OVERALL UNIT HEIGHT OF 37'-1/2", A GROSS UNIT WEIGHT OF 1,179 POUNDS, AND A UNIT CUBE OF 44.8 CUBIC FEET. ADDITIONALLY, THE UNIT MAY BE MODIFIED AS DESCRIBED WHEN BEING SHIPPED BY MILVAN OR ISO INTERMODAL FREIGHT CONTAINER. THE DETERMINATION TO REDUCE THE LOAD BY ONE OR TWO LAYERS FOR TRANSPORTATION WILL BE MADE BY THE RESPONSIBLE COMMAND AND WILL BE BASED UPON ECONOMICS OF TRANSPORTATION AND HANDLING.
- K. FOR DETAILS OF THE PPP-B-621 WOODEN BOX SEE SPI NO. F01-083-0323.

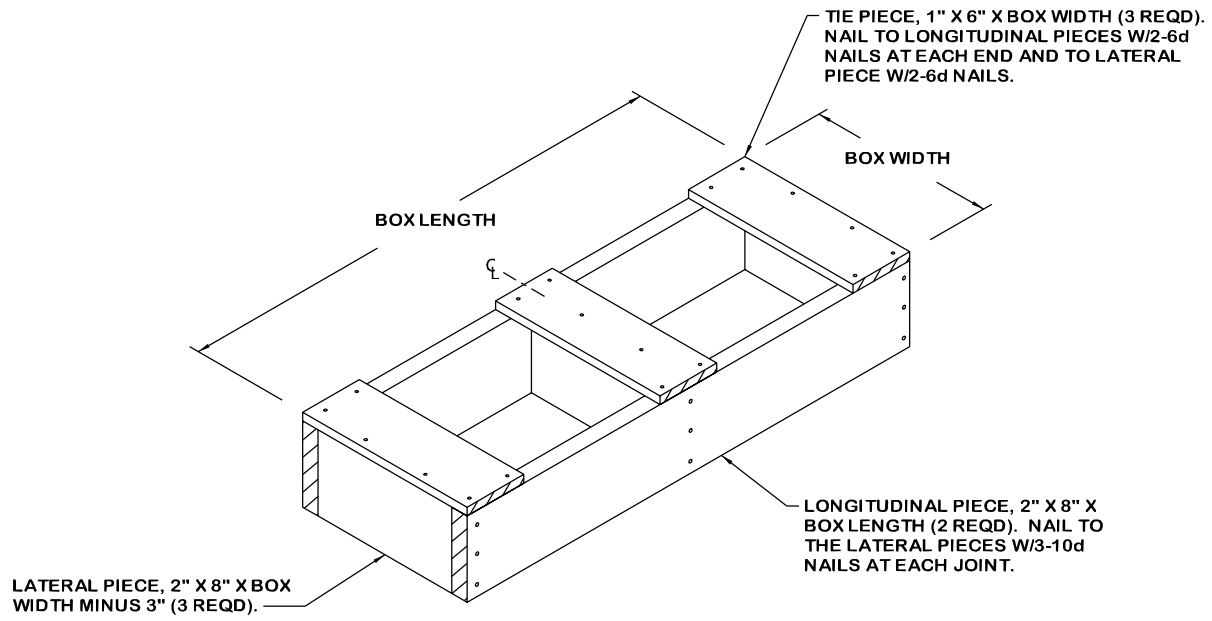

FILLER ASSEMBLY

(FOR MINUS ONE BOX)