

# APPENDIX 110K

## UNITIZING PROCEDURES FOR BOXED AMMUNITION AND COMPONENTS ON 4-WAY ENTRY PALLETS

FLARE, COUNTERMEASURE, PACKED 24 PER  
WOODEN BOX, UNITIZED 18 BOXES PER 40" X  
48" PALLET; APPROX BOX SIZE 20-1/2" L X  
16-3/8" W X 11-3/4" H

NOTICE: THIS APPENDIX CANNOT STAND ALONE BUT MUST BE USED IN CONJUNCTION WITH  
THE BASIC UNITIZATION PROCEDURES DRAWING 19-48-4116-20PA1002

DISTRIBUTION STATEMENT A.

APPROVED FOR PUBLIC RELEASE:  
DISTRIBUTION IS UNLIMITED.

U. S. ARMY MATERIEL COMMAND DRAWING			
APPROVED, U. S. ARMY INDUSTRIAL OPERATIONS COMMAND	DRAFTSMAN	BETTY KUNDERT	
<i>David W. Piskun</i> AMSTA-AR-ESK	ENGINEER	SANDRA M. SCHULTZ	
<i>Timothy J. Fox</i> AMSIO-TMJ	SUPPLY ENGINEERING DIVISION	TRANSPORTATION ENGINEERING DIVISION	VALIDATION ENGINEERING DIVISION
APPROVED BY ORDER OF COMMANDING GENERAL, U. S. ARMY MATERIEL COMMAND	LOGISTICS ENGINEERING OFFICE		
<i>Arthur Podsiadlo</i> U. S. ARMY DEFENSE AMMUNITION CENTER	<i>William F. Ernst</i> NOVEMBER 1997		
	CLASS	DIVISION	DRAWING
	19	48	4116/ 110K
			FILE
			20PA 1002

DO NOT SCALE

PALLET UNIT DATA				
ITEMS INCLUDED		HAZARD CLASS AND DIVISION ●		APPROX WEIGHT LBS
NSN	DODIC	OD CLASS	COMP GROUP	
1370-01-263-1602	L461	1.3	G	1,527

● HAZARD CLASSIFICATION DATA CONTAINED IN THE ABOVE CHART IS FOR GUIDANCE AND INFORMATIONAL PURPOSES ONLY. VERIFICATION OF THE SPECIFIED DATA SHOULD BE MADE BY CONSULTING THE MOST RECENT JOINT HAZARD CLASSIFICATION SYSTEM LISTING OR OTHER APPROVED LISTING(S).

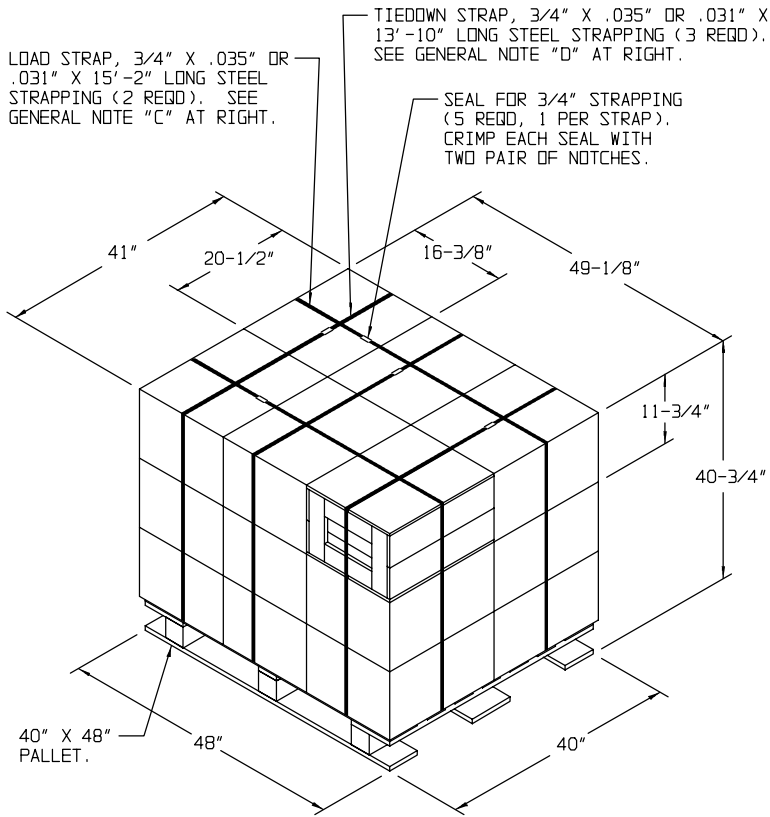

**PALLET UNIT**

SEE GENERAL NOTE "B" AT RIGHT.

18 BOXES OF FLARES (24 PER BOX) AT 80 LBS	---	1,440 LBS (APPROX)
DUNNAGE	-----	7 LBS
PALLET	-----	80 LBS
TOTAL WEIGHT		----- 1,527 LBS (APPROX)
CUBE		----- 47.5 CU FT (APPROX)

**BILL OF MATERIAL**

PALLET, 40" X 48"	-----	1 REQD	-----	80 LBS
STEEL STRAPPING, 3/4"	-----	71.84' REQD	-----	6.42 LBS
SEAL FOR 3/4" STRAPPING	---	5 REQD	-----	NIL

**GENERAL NOTES**

- A. THIS APPENDIX CANNOT STAND ALONE BUT MUST BE USED IN CONJUNCTION WITH THE BASIC UNITIZATION PROCEDURES DRAWING 19-48-4116-20PA1002. TO PRODUCE AN APPROVED UNIT LOAD, ALL PERTINENT PROCEDURES, SPECIFICATIONS AND CRITERIA SET FORTH WITHIN THE BASIC DRAWING WILL APPLY TO THE PROCEDURES DELINEATED IN THIS APPENDIX. ANY EXCEPTIONS TO THE BASIC PROCEDURES ARE SPECIFIED IN THIS APPENDIX.
- B. DIMENSIONS, CUBE AND WEIGHT OF A PALLET UNIT WILL VARY SLIGHTLY DEPENDING UPON THE ACTUAL DIMENSIONS OF THE BOXES AND THE WEIGHT OF THE SPECIFIC ITEM BEING UNITIZED.
- C. THE LOAD STRAPS MUST BE PRE-POSITIONED ON THE PALLET DECK PRIOR TO PLACING BOXES ON THE PALLET. LOAD STRAPS MUST BE TENSIONED AND SEALED PRIOR TO APPLICATION OF TIEDOWN STRAPS.
- D. INSTALL EACH TIEDOWN STRAP TO PASS UNDER THE DECK BOARDS OF THE PALLET AND TO BE LOCATED AS SHOWN. TIEDOWN STRAPS WILL NOT BE APPLIED UNTIL THE LOAD STRAPS HAVE BEEN TENSIONED AND SEALED.
- E. THE FOLLOWING AMC DRAWINGS ARE APPLICABLE FOR UNLOADING AND STORAGE OF THE ITEMS COVERED BY THIS APPENDIX.
  - CARLOADING - - - - 19-48-4115-5PA1002
  - TRUCKLOADING - - - 19-48-4117-11PA1003
  - STORAGE - - - - - 19-48-4118-1-2-3-4-14-22PA1002
  - END OPENING ISD
  - CONTAINER - - - - 19-48-4153-15PA1002
  - MILVAN - - - - - 19-48-4166-15PA1003
  - SIDE OPENING ISD
  - CONTAINER - - - - 19-48-4267-15PA1009
- F. IF ITEMS COVERED HEREIN ARE UNITIZED PRIOR TO ISSUANCE OF THIS APPENDIX, THE BOXES NEED NOT BE REUNITIZED SOLELY TO CONFORM TO THIS APPENDIX.
- G. THE UNITIZATION PROCEDURES DEPICTED HEREIN MAY ALSO BE USED FOR UNITIZING FLARES WHEN IDENTIFIED BY DIFFERENT NATIONAL STOCK NUMBERS (NSN) THAN WHAT IS SHOWN ON PAGE 2, PROVIDED THE BOX PACK DOES NOT VARY FROM WHAT IS DELINEATED HEREIN. THE EXPLOSIVE CLASSIFICATION OF OTHER ITEMS MAY BE DIFFERENT THAN WHAT IS SHOWN.
- H. THE STYLE 1 PALLET DELINEATED IN THE DETAIL AT LEFT NEED NOT HAVE CHAMFERS OR STRAP SLOTS AS SPECIFIED WITHIN MILITARY SPECIFICATION MIL-P-15011 WHEN USED FOR THE UNITIZATION OF ITEMS COVERED BY THIS APPENDIX.
- J. FOR DETAILS OF THE PPP-B-621 STYLE 2, CLASS 2 WOODEN BOX SEE SPI NO. 01-263-1602.

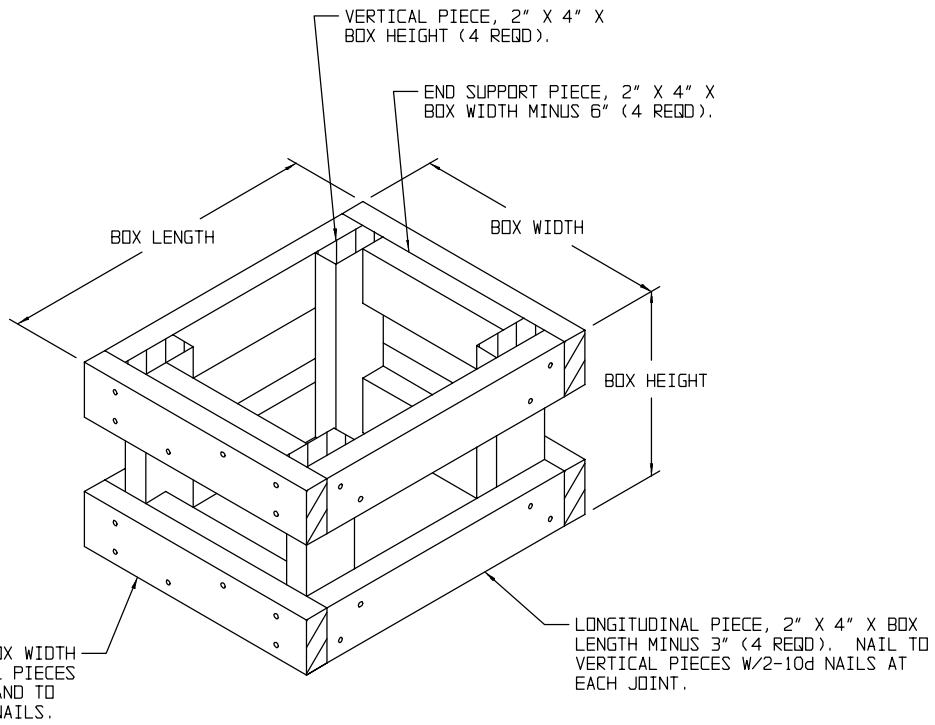

FILLER ASSEMBLY