

# APPENDIX 110J

## UNITIZATION PROCEDURES FOR BOXED AMMUNITION AND COMPO- NENTS ON 4-WAY ENTRY PALLETS

**FLARE, AIRCRAFT OR FLARE, TARGET PACKED 4  
PER WOODEN BOX, UNITIZED 9 BOXES PER 40" X 48"  
PALLET; APPROX BOX SIZE 43" L X 16" W X 15" H**

**NOTICE: THIS APPENDIX CANNOT STAND ALONE BUT MUST BE USED IN CONJUNCTION WITH THE BASIC UNITIZATION  
PROCEDURES DRAWING 19-48-4116-20PA1002.**

**DISTRIBUTION STATEMENT A:**

**APPROVED FOR PUBLIC RELEASE  
DISTRIBUTION IS UNLIMITED.**

### U.S. ARMY MATERIEL COMMAND DRAWING

<p><b>APPROVED, U.S. ARMY RESEARCH, DEVELOPMENT AND ENGINEERING COMMAND</b></p> <p>REHMSTEDT.MA RK.J.1230548400</p> <p><small>Digitally signed by REHMSTEDT.MARK.J.1230548400 DN: cn=US, o=U.S. Government, ou=DoD, ou=PKI, ou=USA, c=US, email=REHMSTEDT.MARK.J.1230548400 Date: 2013.12.31 12:05:49 -06'00'</small></p> <p style="text-align: right;"><b>RDAR-EIL-TP</b></p>	<p><b>CAUTION: VERIFY PRIOR TO USE AT WWW.DAC.ARMY.MIL THAT THIS IS THE MOST CURRENT VERSION OF THIS DOCUMENT. THIS IS PAGE 1 OF 4.</b></p>		<p><b>OCTOBER 1994</b></p>			
<p><b>APPROVED, U.S. ARMY JOINT MUNITIONS COMMAND</b></p> <p>CASILLAS.GILB ERT.J.12303936 44</p> <p><small>Digitally signed by CASILLAS.GILBERT.J.1230393644 DN: cn=US, o=U.S. Government, ou=DoD, ou=PKI, ou=USA, c=US, email=CASILLAS.GILBERT.J.1230393644 Date: 2014.01.09 12:37:18 -06'00'</small></p> <p style="text-align: right;"><b>AMSJM-LIT</b></p>	<p><b>DO NOT SCALE</b></p>	<p><b>REVISION NO. 2</b></p>		<p><b>JANUARY 2014</b></p>		
<p><b>APPROVED BY ORDER OF COMMANDING GENERAL, U.S. ARMY MATERIEL COMMAND</b></p> <p>SHIMP.UPTON .R.1231257183</p> <p><small>Digitally signed by SHIMP.UPTON.R.1231257183 DN: cn=US, o=U.S. Government, ou=DoD, ou=PKI, ou=USA, c=US, email=SHIMP.UPTON.R.1231257183 Date: 2014.01.13 11:10:28 -06'00'</small></p> <p style="text-align: center;"><b>U.S. ARMY DEFENSE AMMUNITION CENTER</b></p>	<p><b>TRANSPORTATION ENGINEERING DIVISION</b></p> <p><b>VALIDATION ENGINEERING DIVISION</b></p> <p><b>EXPLOSIVE SAFETY DIRECTORATE</b></p>	<p><b>FIEFFER.LAUR A.A.1230375727</b></p> <p><small>Digitally signed by FIEFFER.LAURA.A.1230375727 DN: cn=US, o=U.S. Government, ou=DoD, ou=PKI, ou=USA, c=US, email=FIEFFER.LAURA.A.1230375727 Date: 2012.08.08 12:54:44 -05'00'</small></p> <p><b>GORDON.WA LTER.G.12395 83268</b></p> <p><small>Digitally signed by GORDON.WALTER.G.1239583268 DN: cn=US, o=U.S. Government, ou=DoD, ou=PKI, ou=USA, c=US, email=GORDON.WALTER.G.1239583268 Date: 2012.08.09 14:02:58 -05'00'</small></p> <p><b>TESTED</b></p> <p><b>WILLIAMS.KENY ON.L.1231212392</b></p> <p><small>Digitally signed by WILLIAMS.KENYON.L.1231212392 DN: cn=US, o=U.S. Government, ou=DoD, ou=PKI, ou=USA, c=US, email=WILLIAMS.KENYON.L.1231212392 Date: 2012.08.16 09:29:08 -05'00'</small></p>	<p><b>CLASS</b></p> <p style="text-align: center;"><b>19</b></p>	<p><b>DIVISION</b></p> <p style="text-align: center;"><b>48</b></p>	<p><b>DRAWING</b></p> <p style="text-align: center;"><b>4116/ 110J</b></p>	<p><b>FILE</b></p> <p style="text-align: center;"><b>20PA1002</b></p>

PALLET UNIT DATA				
ITEMS INCLUDED		*HAZARD CLASS AND DIVISION	*COMPATI- BILITY GROUP	APPROX WEIGHT (LBS)
NSN	DODIC			
1370-				
01-331-3485	L440	1.3	G	1,843
01-483-2406	L440	1.3	G	1,843
01-537-9031	L440	1.3	G	1,612
01-335-5053	L443	1.3	G	1,843
01-335-6075	L660	1.3	G	1,843
01-335-6074	L661	1.3	G	1,843
01-537-9304	LA29	1.3	G	1,828

\*HAZARD CLASSIFICATION DATA CONTAINED IN THE ABOVE CHART IS FOR GUIDANCE AND INFORMATIONAL PURPOSES ONLY. VERIFICATION OF THE SPECIFIED DATA SHOULD BE MADE BY CONSULTING THE MOST RECENT JOINT HAZARD CLASSIFICATION SYSTEM LISTING OR OTHER APPROVED LISTING(S).

### REVISIONS

REVISION NO. 1, DATED JULY 2003, CONSISTS OF:

1. ADDING ITEM BY NATIONAL STOCK NUMBER (NSN) TO "PALLET UNIT DATA" CHART.
2. ADDING GENERAL NOTE WITH BOX DRAWING REFERENCE AND ELIMINATE STRAP CUTTER GENERAL NOTE.

REVISION NO. 2, DATED JANUARY 2014, CONSISTS OF CHANGES PER ECP R11K3002 INCLUDING:

1. ADDING ITEM BY NATIONAL STOCK NUMBER (NSN) TO "PALLET UNIT DATA" CHART.
2. ADDING GENERAL NOTE WITH BOX DRAWING REFERENCE.
3. ADDING NEW STRAP THICKNESS TO UNITIZATION TIEDOWN AND LOAD STRAPS.

**GENERAL NOTES**

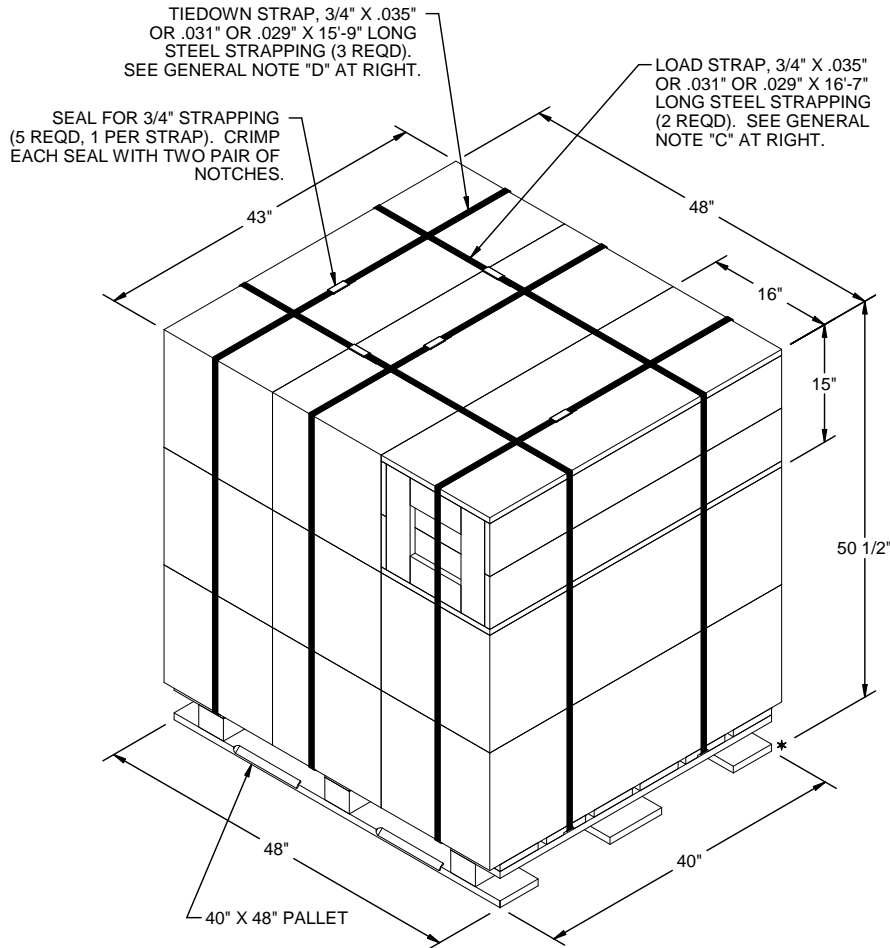

**PALLET UNIT**

SEE GENERAL NOTE "B" AT RIGHT.

- A. THIS APPENDIX CANNOT STAND ALONE BUT MUST BE USED IN CONJUNCTION WITH THE BASIC UNITIZATION PROCEDURES DRAWING 19-48-4116-20PA1002. TO PRODUCE AN APPROVED UNIT LOAD, ALL PERTINENT PROCEDURES, SPECIFICATIONS AND CRITERIA SET FORTH WITHIN THE BASIC DRAWING WILL APPLY TO THE PROCEDURES DELINEATED IN THIS APPENDIX. ANY EXCEPTIONS TO THE BASIC PROCEDURES ARE SPECIFIED IN THIS APPENDIX.
- B. DIMENSIONS, CUBE AND WEIGHT OF A PALLET UNIT WILL VARY SLIGHTLY DEPENDING UPON THE ACTUAL DIMENSIONS OF THE BOXES AND THE WEIGHT OF THE SPECIFIC ITEM BEING UNITIZED.
- C. THE LOAD STRAPS MAY BE THREADED THROUGH THE STRAP SLOTS OF A PALLET OR PRE-POSITIONED ON THE PALLET DECK PRIOR TO PLACING THE BOXES ON THE PALLET. LOAD STRAPS MUST BE TENSIONED AND SEALED PRIOR TO APPLICATION OF TIEDOWN STRAPS.
- D. INSTALL EACH TIEDOWN STRAP TO PASS UNDER THE TOP DECK BOARDS OF THE PALLET AND TO BE LOCATED AS SHOWN. TIEDOWN STRAPS WILL NOT BE APPLIED UNTIL THE LOAD STRAPS HAVE BEEN TENSIONED AND SEALED.
- E. THE FOLLOWING AMC DRAWINGS ARE APPLICABLE FOR OUTLOADING AND STORAGE OF THE ITEMS COVERED BY THIS APPENDIX.
 

CARLOADING	- - - -	19-48-4115-5PA1002
TRUCKLOADING	- - - -	19-48-4117-11PA1003
STORAGE	- - - -	19-48-4118-1-2-3-4-14-22PA1002
END OPENING ISO		
CONTAINER	- - - -	19-48-4153-15PA1002
MILVAN	- - - -	19-48-4166-15PA1003
SIDE OPENING ISO		
CONTAINER	- - - -	19-48-4267-15PA1009
- F. IF ITEMS COVERED HEREIN ARE UNITIZED PRIOR TO ISSUANCE OF THIS REVISION TO THIS APPENDIX, THE BOXES NEED NOT BE REUNITIZED SOLELY TO CONFORM TO THIS REVISION.
- G. THE UNITIZATION PROCEDURES DEPICTED HEREIN MAY ALSO BE USED FOR UNITIZING FLARES WHEN IDENTIFIED BY DIFFERENT NATIONAL STOCK NUMBERS (NSN) THAN WHAT IS SHOWN ON PAGE 2, PROVIDED THE BOX PACK DOES NOT VARY FROM WHAT IS DELINEATED HEREIN. THE EXPLOSIVE CLASSIFICATION OF OTHER ITEMS MAY BE DIFFERENT THAN WHAT IS SHOWN.
- H. THE STYLE 1 PALLET DELINEATED IN THE DETAIL AT LEFT NEED NOT HAVE CHAMFERS OR STRAP SLOTS AS SPECIFIED WITHIN MILITARY SPECIFICATION MIL-DTL-15011 WHEN USED FOR THE UNITIZATION OF ITEMS COVERED BY THIS APPENDIX.
- J. FOR DETAILS OF THE ASTM D6880 WOOD BOX SEE AIR FORCE DRAWING SPI 01-331-3485.

9 BOXES OF FLARES (4 PER BOX) @ 195 LBS	1,755 LBS (APPROX)
DUNNAGE	8 LBS
PALLET	80 LBS
<hr style="border: 1px solid black;"/>	
TOTAL WEIGHT	1,843 LBS (APPROX)
CUBE	60.3 CU FT (APPROX)

BILL OF MATERIAL	
PALLET, 40" X 48"	1 REQD - 80 LBS
STEEL STRAPPING, 3/4"	80.42' REQD - 7.18 LBS
SEAL FOR 3/4" STRAPPING	5 REQD - NIL

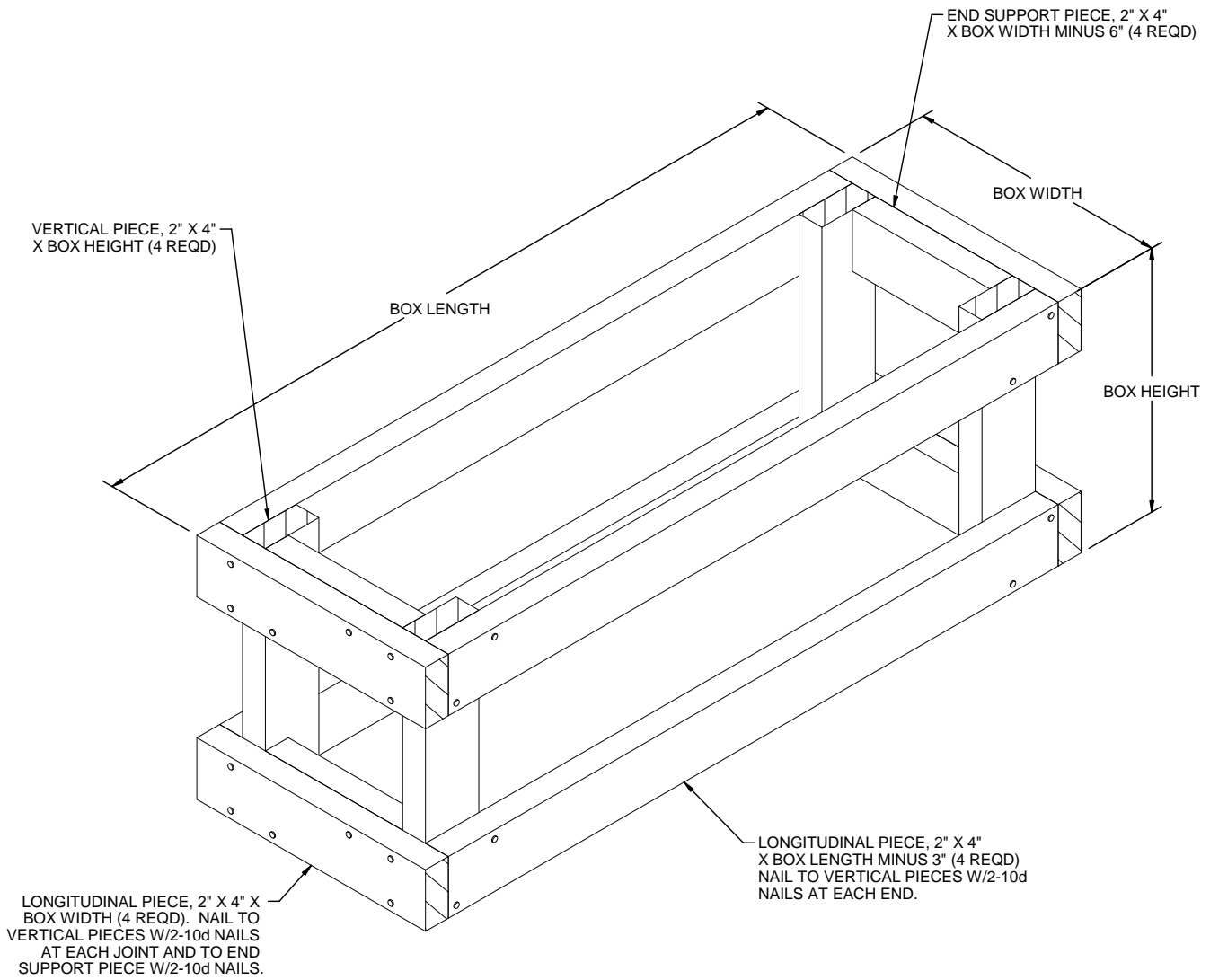

**FILLER ASSEMBLY**  
(FOR MINUS ONE BOX)