

APPENDIX 107U

UNITIZATION PROCEDURES FOR BOXED AMMUNITION AND COMPONENTS ON 4-WAY ENTRY PALLETS

SIGNAL, SMOKE AND ILLUMINATING MK 13 MOD 0,
PACKED 36 PER WOODEN BOX, UNITIZED 48
BOXES PER 40" X 48" PALLET; APPROX BOX
SIZE 14 $\frac{1}{2}$ " L X 12 $\frac{3}{4}$ " W X 8 $\frac{3}{4}$ " H

PALLET UNIT DATA						
ITEMS INCLUDED		HAZARD CLASSIFICATION ①				WEIGHT
NSN	DODIC	DOT CLASS	CG CLASS	QD CLASS	COMP GROUP	(LBS)
1370-00-567-2817	L275	C	II-C	1.4	G	1,816

NOTICE: THIS APPENDIX CANNOT STAND ALONE BUT MUST BE
USED IN CONJUNCTION WITH THE BASIC UNITIZATION PROCEDURES
DRAWING 19-48-4116-20PA1002.

- ① HAZARD CLASSIFICATION DATA CONTAINED IN THE ABOVE CHART IS FOR GUIDANCE AND INFORMATIONAL PURPOSES ONLY. VERIFICATION OF THE SPECIFIED DATA SHOULD BE MADE BY CONSULTING THE MOST RECENT JOINT HAZARD CLASSIFICATION SYSTEM LISTING OR OTHER APPROVED LISTING(S).

DO NOT SCALE

REVISIONS				DRAFTSMAN <i>Dier</i>	PROJ ENG <i>DS</i>	CHECKER <i>GRE</i>	LOG ENGRG OFFICE <i>W. J. Covert</i>
				APPROVED, U.S. ARMY ARMAMENT, SHIFTS AND CHEMICAL COMMAND <i>K. E. Martin</i> <i>J. L. Bryant</i>			
				APPROVED BY ORDER OF COMMANDING GENERAL, U.S. ARMY MATERIAL COMMAND (AMC) <i>John L. Bryant</i> U.S. ARMY DEFENSE AMMUNITION CENTER AND SCHOOL			
U.S. ARMY AMC DRAWING							
JANUARY 1985							
	CLASS	DIVISION	DRAWING	FILE			
	19	48	4116/ 107U	20PA 1002			

TIEDOWN STRAP, 3/4" X .035" OR .031" X 14'-2" LONG STEEL STRAPPING (4 REQD). SEE GENERAL NOTE "D" AT RIGHT.

SEAL FOR 3/4" STRAPPING (7 REQD, 1 PER STRAP). CRIMP EACH SEAL WITH TWO PAIR OF NOTCHES.

LOAD STRAP, 3/4" X .035" OR .031" X 15'-5" LONG STEEL STRAPPING (3 REQD). SEE GENERAL NOTE "C" AT RIGHT.

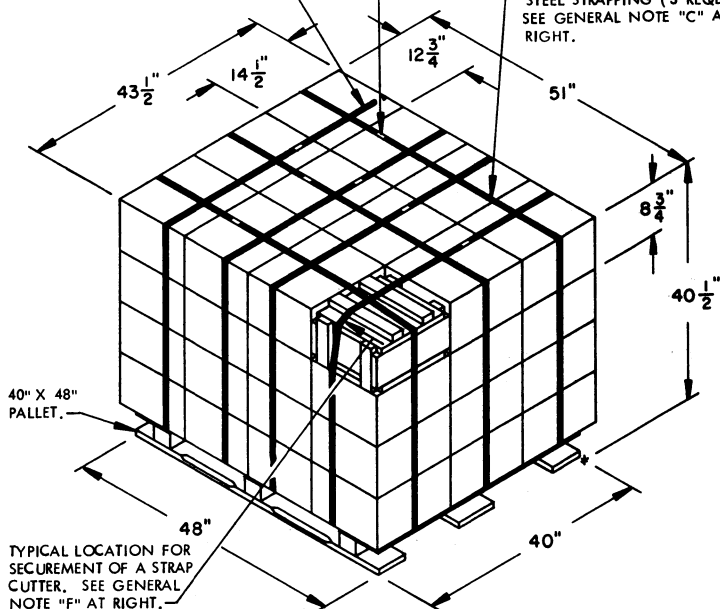

PALLET UNIT

SEE GENERAL NOTE "B" AT RIGHT.

48 BOXES OF SIGNALS (36 PER BOX) @ 36 LBS -----	1,728 LBS (APPROX)
DUNNAGE -----	8 LBS
PALLET -----	80 LBS
TOTAL WEIGHT -----	1,816 LBS (APPROX)
CUBE -----	52.0 CU FT (APPROX)

GENERAL NOTES

- A. THIS APPENDIX CANNOT STAND ALONE BUT MUST BE USED IN CONJUNCTION WITH THE BASIC UNITIZATION PROCEDURES DRAWING 19-48-4116-20PA1002. TO PRODUCE AN APPROVED UNIT LOAD, ALL PERTINENT PROCEDURES, SPECIFICATIONS AND CRITERIA SET FORTH WITHIN THE BASIC DRAWING WILL APPLY TO THE PROCEDURES DELINEATED IN THIS APPENDIX. ANY EXCEPTIONS TO THE BASIC PROCEDURES ARE SPECIFIED IN THIS APPENDIX.
- B. DIMENSIONS, CUBE AND WEIGHT OF A PALLET UNIT WILL VARY SLIGHTLY DEPENDING UPON THE ACTUAL DIMENSIONS OF THE BOXES AND THE WEIGHT OF THE SPECIFIC ITEM BEING UNITIZED.
- C. THE LOAD STRAPS WILL BE PRE-POSITIONED ON THE PALLET DECK PRIOR TO PLACING BOXES ON THE PALLET. LOAD STRAPS MUST BE TENSIONED AND SEALED PRIOR TO APPLICATION OF TIEDOWN STRAPS.
- D. INSTALL EACH TIEDOWN STRAP TO PASS UNDER THE TOP DECK BOARDS OF THE PALLET AND TO BE LOCATED AS SHOWN. TIEDOWN STRAPS WILL NOT BE APPLIED UNTIL THE LOAD STRAPS HAVE BEEN TENSIONED AND SEALED.
- E. THE FOLLOWING AMC (DARCOM) DRAWINGS ARE APPLICABLE FOR OUTLOADING AND STORAGE OF THE ITEMS COVERED BY THIS APPENDIX.
 CARLOADING ----- DRAWING 19-48-4115-5PA1002.
 TRUCKLOADING ----- DRAWING 19-48-4117-11PA1003.
 STORAGE ----- DRAWING 19-48-4118-1-2-3-4-14-22PA1002.
- F. FOR METHOD OF SECURING A STRAP CUTTER TO THE PALLET UNIT, SEE DARCOM DRAWING 19-48-4127-20P1000.
- G. IF ITEMS COVERED HEREIN ARE UNITIZED PRIOR TO ISSUANCE OF THIS APPENDIX, THE BOXES NEED NOT BE REUNITIZED SOLELY TO CONFORM TO THIS APPENDIX.
- H. THE UNITIZATION PROCEDURES DEPICTED HEREIN MAY ALSO BE USED FOR UNITIZING SIGNALS WHEN IDENTIFIED BY DIFFERENT NATIONAL STOCK NUMBERS (NSN) THAN WHAT IS SHOWN ON THE TITLE PAGE, PROVIDED THE BOX PACK DOES NOT VARY FROM WHAT IS DELINEATED HEREIN. THE EXPLOSIVE CLASSIFICATION OF OTHER ITEMS MAY BE DIFFERENT THAN WHAT IS SHOWN.

BILL OF MATERIAL

PALLET, 40" X 48" -----	1 REQD -----	80 LBS
STEEL STRAPPING, 3/4" -----	102.92' REQD -----	7.35 LBS
SEAL FOR 3/4" STRAPPING -----	7 REQD -----	NIL

TIE PIECE, 1" X 4" X BOX WIDTH (2 REQD). NAIL TO LONGITUDINAL PIECES W/2-6d NAILS AT EACH END AND TO LATERAL PIECE W/1-6d NAIL.

VERTICAL PIECE, 2" X 4" X BOX HEIGHT MINUS 3/4" (4 REQD).

SUPPORT PIECE, 2" X 2" (RIPPED TO FIT) BY BOX LENGTH. NAIL TO THE VERTICAL PIECES W/2-10d NAILS AT EACH LOCATION (AS REQD). NOTE: WHEN A FILLER ASSEMBLY OR ASSEMBLIES ARE LOCATED IN AN OUTER STACK ON THE 40" SIDE OR SIDES OF THE PALLET IT WILL REQUIRE A SUPPORT PIECE AS SHOWN.

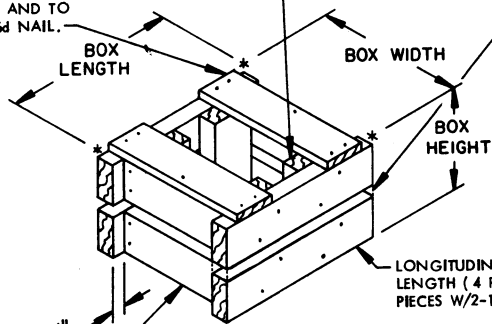

LONGITUDINAL PIECE, 2" X 4" X BOX LENGTH (4 REQD). NAIL TO VERTICAL PIECES W/2-10d NAILS AT EACH END.

LATERAL PIECE, 2" X 4" X BOX WIDTH MINUS 3" (4 REQD). NAIL TO VERTICAL PIECES W/2-10d NAILS AT EACH END.

FILLER ASSEMBLY
(FOR MINUS ONE BOX)