

APPENDIX 107L

UNITIZATION PROCEDURES FOR BOXED AMMUNITION AND COMPONENTS ON 4-WAY ENTRY PALLETS

MARKER, LOCATION, PACKED 30 PER WOODEN BOX,
UNITIZED 9 BOXES PER 35" X 45 $\frac{1}{2}$ " PALLET;
APPROX BOX SIZE 33 $\frac{9}{16}$ " L X 16 $\frac{3}{4}$ " W X 15 $\frac{1}{32}$ " H

PALLET UNIT DATA						
ITEMS INCLUDED		HAZARD CLASSIFICATION				WEIGHT (LBS)
NSN	DODIC	DOT CLASS	CG CLASS	QD CLASS	COMP GROUP	
1370- 00-935-6143	L582		INERT			731

⊙ HAZARD CLASSIFICATION DATA CONTAINED IN THE ABOVE CHART IS FOR GUIDANCE AND INFORMATIONAL PURPOSES ONLY. VERIFICATION OF THE SPECIFIED DATA SHOULD BE MADE BY CONSULTING THE MOST RECENT JOINT HAZARD CLASSIFICATION SYSTEM LISTING OR OTHER APPROVED LISTING (S).

REVISIONS

REVISION NO. 1, DATED MARCH 1984, CONSISTS OF

1. CHANGING BOX DIMENSIONS.
2. UPDATING DRAWING FORMAT TO CONFORM TO NUMBER 1 ABOVE.

REVISION NO. 2, DATED MAY 1986, CONSISTS OF:

1. CHANGING BOX DIMENSIONS.
2. UPDATING DRAWING FORMAT TO CONFORM TO NUMBER 1 IMMEDIATELY ABOVE.

NOTICE: THIS APPENDIX CANNOT STAND ALONE BUT MUST BE USED IN CONJUNCTION WITH THE BASIC UNITIZATION PROCEDURES DRAWING 19-48-4116-20PA1002.

DO NOT SCALE

REVISIONS				DATE	BY	APPROVED BY	DATE
1	MAR 84	<i>WBS</i>	<i>WBS</i>		<i>WBS</i>	<i>WBS</i>	
2	MAY 86	<i>WBS</i>	<i>WBS</i>		<i>WBS</i>	<i>WBS</i>	
				APPROVED BY ORDER OF COMMANDING GENERAL, U. S. ARMY MATERIAL DEVELOPMENT AND RESEARCH COMMAND (DARCOM) <i>John L. Boydell</i> U. S. ARMY DEPTDICE ASSAULT CENTER AND SCHOOL			
				U. S. ARMY DARCOM DRAWING JULY 1983			
				CLASS	DIVISION	DRAWING	FILE
				19	48	4116/ 107L	20PA 1002

GENERAL NOTES

- A. THIS APPENDIX CANNOT STAND ALONE BUT MUST BE USED IN CONJUNCTION WITH THE BASIC UNITIZATION PROCEDURES DRAWING 19-48-4116-20PA1002. TO PRODUCE AN APPROVED UNIT LOAD, ALL PERTINENT PROCEDURES, SPECIFICATIONS AND CRITERIA SET FORTH WITHIN THE BASIC DRAWING WILL APPLY TO THE PROCEDURES DELINEATED IN THIS APPENDIX. ANY EXCEPTIONS TO THE BASIC PROCEDURES ARE SPECIFIED IN THIS APPENDIX.
- B. DIMENSIONS, CUBE AND WEIGHT OF A PALLET UNIT WILL VARY SLIGHTLY DEPENDING UPON THE ACTUAL DIMENSIONS OF THE BOXES AND THE WEIGHT OF THE SPECIFIC ITEM BEING UNITIZED.
- C. THE LOAD STRAPS MAY BE THREADED THROUGH THE STRAP SLOTS OF A PALLET OR PRE-POSITIONED ON THE PALLET DECK PRIOR TO PLACING BOXES ON THE PALLET. LOAD STRAPS MUST BE TENSIONED AND SEALED PRIOR TO APPLICATION OF TIEDOWN STRAPS.
- D. INSTALL EACH TIEDOWN STRAP TO PASS UNDER THE TOP DECK BOARDS OF THE PALLET AND TO BE LOCATED AS SHOWN. TIEDOWN STRAPS WILL NOT BE APPLIED UNTIL THE LOAD STRAPS HAVE BEEN TENSIONED AND SEALED.
- E. THE FOLLOWING AMC (DARCOM) DRAWINGS ARE APPLICABLE FOR OUTLOADING AND STORAGE OF THE ITEMS COVERED BY THIS APPENDIX.
 CARLOADING — DRAWING 19-48-4115-5PA1002
 TRUCKLOADING — DRAWING 19-48-4117-11PA1003
 STORAGE — DRAWING 19-48-4118-1-2-3-4-14-22PA1002
- F. FOR METHOD OF SECURING A STRAP CUTTER TO THE PALLET UNIT, SEE DARCOM DRAWING 19-48-4127-20P1000.
- G. IF ITEMS COVERED HEREIN ARE UNITIZED PRIOR TO ISSUANCE OF THIS APPENDIX, THE BOXES NEED NOT BE REUNITIZED SOLELY TO CONFORM TO THIS APPENDIX.
- H. THE UNITIZATION PROCEDURES DEPICTED HEREIN MAY ALSO BE USED FOR UNITIZING MARKER, LOCATION WHEN IDENTIFIED BY DIFFERENT NATIONAL STOCK NUMBERS (NSN) THAN WHAT IS SHOWN ON THE TITLE PAGE, PROVIDED THE BOX PACK DOES NOT VARY FROM WHAT IS DELINEATED HEREIN. THE EXPLOSIVE CLASSIFICATION OF OTHER ITEMS MAY BE DIFFERENT THAN WHAT IS SHOWN.
- J. WHEN THE UNIT LOAD DEPICTED AT LEFT IS TO BE USED FOR UNITIZING MARINE CORPS AMMUNITION, ONE LAYER OF BOXES MUST BE OMITTED, TIEDOWN STRAP LENGTHS MUST BE DECREASED TO 12'-0", LOAD STRAP LENGTHS MUST BE DECREASED TO 14'-6", AND BATTEN LENGTHS MUST BE DECREASED TO 30". THIS WILL RESULT IN AN OVERALL UNIT HEIGHT OF 35-1/2", A GROSS UNIT WEIGHT OF 511 POUNDS, AND A UNIT CUBE OF 36.6 CUBIC FEET. ADDITIONALLY, THE UNIT LOAD MAY BE MODIFIED AS DESCRIBED WHEN BEING SHIPPED BY MILVAN OR COMMERCIAL INTERMODAL FREIGHT CONTAINER. THE DETERMINATION TO REDUCE THE LOAD BY A LAYER FOR TRANSPORTATION WILL BE MADE BY THE RESPONSIBLE COMMAND AND WILL BE BASED UPON ECONOMICS OF TRANSPORTATION AND HANDLING.

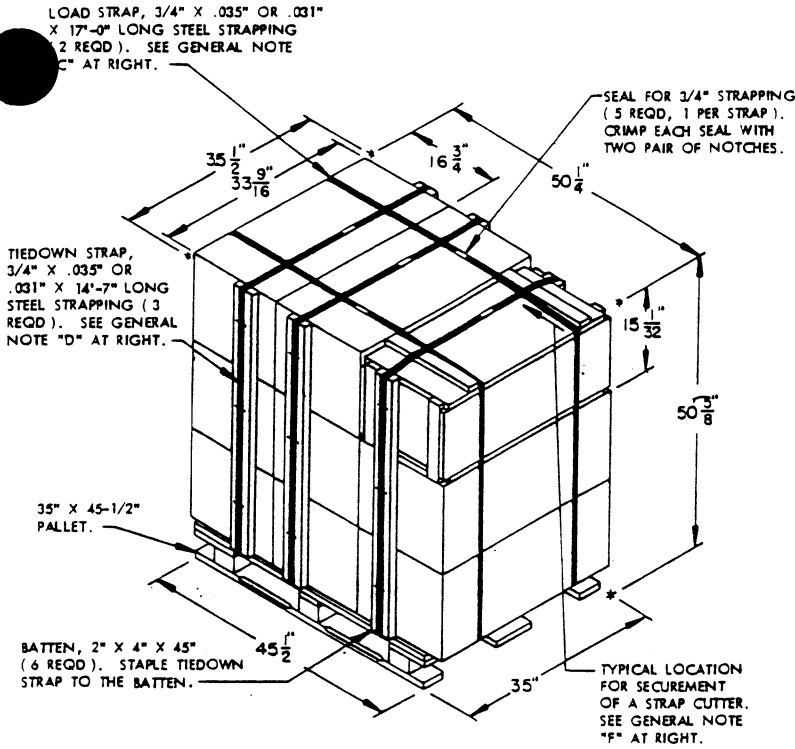

PALLET UNIT

SEE GENERAL NOTE "B" AT RIGHT.

9 BOXES OF MARKERS (30 PER BOX) @ 70 LBS	630 LBS (APPROX)
DUNNAGE	36 LBS
PALLET	65 LBS
TOTAL WEIGHT	731 LBS (APPROX)
CUBE	52.3 CU FT (APPROX)

BILL OF MATERIAL		
LUMBER	LINEAR FEET	BOARD FEET
2" X 4"	22.50	15.00
PALLET, 35" X 45-1/2"	1 REQ	65 LBS
STEEL STRAPPING, 3/4"	77.75' REQ	5.55 LBS
SEAL FOR 3/4" STRAPPING	5 REQ	NIL
STAPLE, 15/16" X 3/4"	18 REQ	NIL

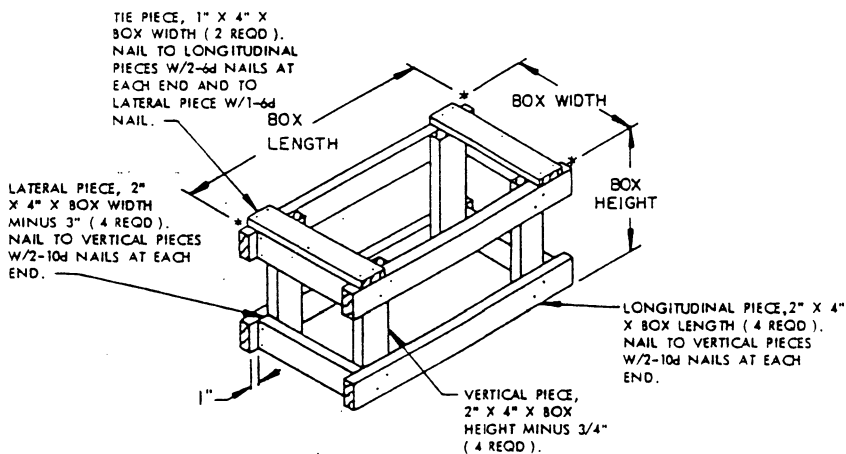

FILLER ASSEMBLY

(FOR MINUS ONE BOX)