

APPENDIX 107B

UNITIZATION PROCEDURES FOR BOXED AMMUNITION AND COMPONENTS ON 4-WAY ENTRY PALLETS

SIGNAL, ILLUMINATION, PACKED 1,250 PER WOODEN
BOX, UNITIZED 20 BOXES PER 40" X 48" PALLET;
APPROX BOX SIZE $21\frac{5}{8}$ " L X $15\frac{3}{4}$ " W X $10\frac{1}{2}$ " H

PALLET UNIT DATA						
ITEMS INCLUDED		HAZARD CLASSIFICATION				WEIGHT (LBS)
NSN	DODIC	DOT CLASS	CG CLASS	QD CLASS	COMP GROUP	
1370-						
00-921-6118	L278	C	II-C	1.3	G	1,708
00-921-6119	L279	C	II-C	1.3	G	1,708
00-921-6120	L280	C	II-C	1.3	G	1,708
00-921-6121	L281	C	II-C	1.3	G	1,708

NOTICE: THIS APPENDIX CANNOT STAND ALONE BUT MUST BE USED IN CONJUNCTION WITH THE BASIC UNITIZATION PROCEDURES DRAWING 19-48-4116-20PA1002.

REVISION

REVISION NO. 1, DATED FEBRUARY 1982, CONSISTS OF:
ADDING ITEM BY NATIONAL STOCK NUMBER TO "PALLET
UNIT DATA" CHART.

REVISIONS				PROJECT MANAGER	PROJ ENG
1	FEB 82	WRF WAB	WAB WAB	RSH	John Boyd
				APPROVED, U. S. ARMY ARMAMENT MATERIEL READINESS COMMAND	
				DRSAR - MAD	DRSAR - TMD
APPROVED BY ORDER OF COMMANDING GENERAL, U. S. ARMY MATERIEL DEVELOPMENT AND READINESS COMMAND (DARCOM)					
U. S. ARMY DEFENSE AMMUNITION CENTER AND SCHOOL					
U. S. ARMY DARCOM DRAWING					
JULY 1980					
		CLASS	DIVISION	DRAWING	FILE
		19	48	4116/ 107B	20PA 1002

DO NOT SCALE

GENERAL NOTES

- A. THIS APPENDIX CANNOT STAND ALONE BUT MUST BE USED IN CONJUNCTION WITH THE BASIC UNITIZATION PROCEDURES DRAWING 19-48-4116-20PA1002. TO PRODUCE AN APPROVED UNIT LOAD, ALL PERTINENT PROCEDURES, SPECIFICATIONS AND CRITERIA SET FORTH WITHIN THE BASIC DRAWING WILL APPLY TO THE PROCEDURES DELINEATED IN THIS APPENDIX. ANY EXCEPTIONS TO THE BASIC PROCEDURES ARE SPECIFIED IN THIS APPENDIX.
- B. DIMENSIONS, CUBE AND WEIGHT OF A PALLET UNIT WILL VARY SLIGHTLY DEPENDING UPON THE ACTUAL DIMENSIONS OF THE BOXES AND THE WEIGHT OF THE SPECIFIC ITEM BEING UNITIZED.
- C. INSTALL EACH HORIZONTAL STRAP TO ENCIRCLE A LAYER OF BOXES ON THE PALLET. HORIZONTAL STRAPS MUST BE TENSIONED AND SEALED PRIOR TO APPLICATION OF TIEDOWN STRAPS.
- D. INSTALL EACH TIEDOWN STRAP TO PASS UNDER THE DECK/STRINGER BOARDS OF THE PALLET AND TO BE LOCATED AS SHOWN. TIEDOWN STRAPS WILL NOT BE APPLIED UNTIL THE HORIZONTAL STRAPS HAVE BEEN TENSIONED AND SEALED.
- E. THE FOLLOWING DARCOM DRAWINGS ARE APPLICABLE FOR OUTLOADING AND STORAGE OF THE ITEMS COVERED BY THIS APPENDIX.
 - CARLOADING ----- DRAWING 19-48-4115-5PA1002
 - TRUCKLOADING ----- DRAWING 19-48-4117-11PA1003
 - STORAGE ----- DRAWING 19-48-4118-1-2-3-4-14-22PA1002
- F. FOR METHOD OF SECURING A STRAP CUTTER TO THE PALLET UNIT, SEE DARCOM DRAWING 19-48-4127-20P1000.
- G. IF ITEMS COVERED HEREIN ARE UNITIZED PRIOR TO ISSUANCE OF THIS APPENDIX, THE BOXES NEED NOT BE REUNITIZED SOLELY TO CONFORM TO THIS APPENDIX.
- H. THE UNITIZATION PROCEDURES DEPICTED HEREIN MAY ALSO BE USED FOR UNITIZING SIGNAL, ILLUMINATION WHEN IDENTIFIED BY DIFFERENT NATIONAL STOCK NUMBERS (NSN) THAN WHAT IS SHOWN ON THE TITLE PAGE, PROVIDED THE BOX PACK DOES NOT VARY FROM WHAT IS DELINEATED HEREIN. THE EXPLOSIVE CLASSIFICATION OF OTHER ITEMS MAY BE DIFFERENT THAN WHAT IS SHOWN.

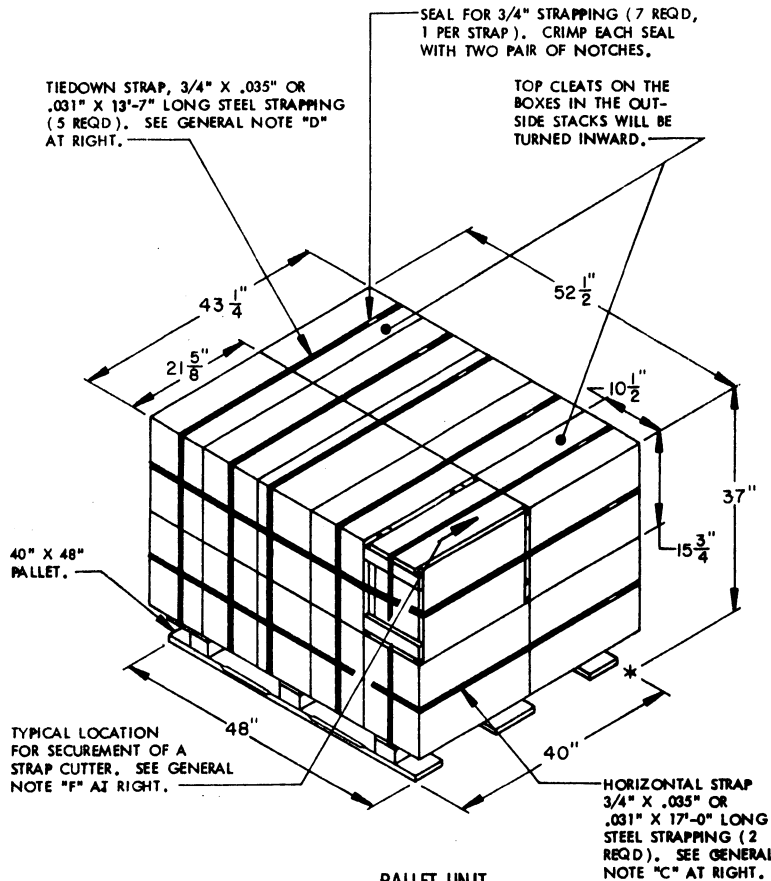

PALLET UNIT
SEE GENERAL NOTE "B" AT RIGHT.

20 BOXES OF SIGNAL, ILLUMINATION (1,250 PER BOX) @ 81 LBS -----	1,620 LBS (APPROX)
DUNNAGE -----	8 LBS
PALLET -----	80 LBS
TOTAL WEIGHT -----	1,708 LBS (APPROX)
CUBE -----	48.6 CU FT (APPROX)

BILL OF MATERIAL		
PALLET, 40" X 48" -----	1 REQD -----	80 LBS
STEEL STRAPPING, 3/4" -----	101.92' REQD -----	7.28 LBS
SEAL FOR 3/4" STRAPPING -----	7 REQD -----	NIL

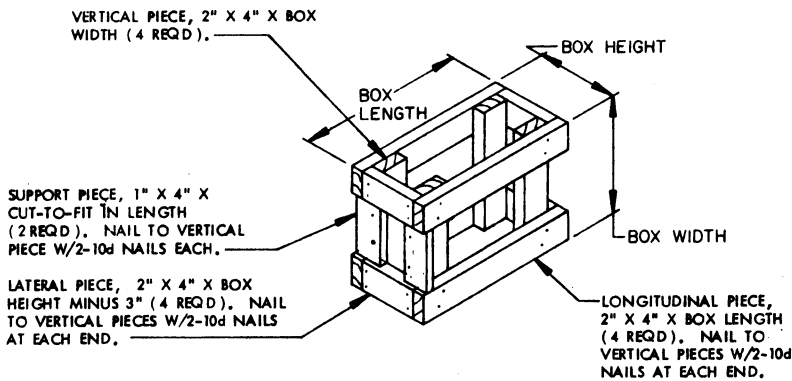

FILLER ASSEMBLY
(FOR MINUS ONE BOX)