

APPENDIX 106

UNITIZATION PROCEDURES FOR BOXED AMMUNITION AND COMPONENTS ON 4-WAY ENTRY PALLETS

CARTRIDGE, PHOTOFLASH, M112, PACKED 40 PER WOODEN
BOX, UNITIZED 24 BOXES PER 35" X 45½" PALLET;
APPROX BOX SIZE 20¼" L X 11¾" W X 11½"

PALLET UNIT DATA						
ITEMS INCLUDED		HAZARD CLASSIFICATION				WEIGHT
NSN	DODIC	DOT CLASS	CG CLASS	QD CLASS	COMP GROUP	(LBS)
1370-00- 028-5924	L136	A	X-B	1,1	G	1,871
028-5923	L135	A	X-B	1,1	G	1,655
322-6382	L135	A	X-B	1,1	G	1,655

NOTICE: THIS APPENDIX CANNOT STAND ALONE BUT MUST BE
USED IN CONJUNCTION WITH THE BASIC UNITIZATION
PROCEDURES DRAWING 19-48-4116-20PA1002.

REVISION

REVISION NO. 1, DATED FEBRUARY 1982, CONSISTS OF:

ADDING ITEM BY NATIONAL STOCK NUMBER TO "PALLET UNIT
DATA" CHART.

DO NOT SCALE

REVISIONS				DRAFTSMAN <i>Toh</i>	PROJ ENG <i>MPD/NUW</i>
1	FEB 82	<i>WRF</i> <i>WFE</i>	<i>John L. Boyd</i>	<i>John L. Boyd</i>	<i>John L. Boyd</i>
				CHECKER <i>John L. Boyd</i>	LOG ENGRS OFFICE <i>John L. Boyd</i>
				APPROVED, U. S. ARMY ARMAMENT MATERIEL READINESS COMMAND	
				<i>Robert V. Smith</i>	<i>Daniel C. Fetter</i>
				DARCOM - MAD	DARCOM - TMA
				APPROVED BY ORDER OF COMMANDING GENERAL, U. S. ARMY MATERIEL DEVELOPMENT AND READINESS COMMAND (DARCOM)	
				<i>DA Egan</i> DARCOM AMMO CENTER	
				U. S. ARMY DARCOM DRAWING	
				APRIL 1977	
		CLASS	DIVISION	DRAWING	FILE
		19	48	4116/106	20PA 1002

LOAD STRAP, 3/4" X .035" OR .031" X 15'-0" LONG STEEL STRAPPING (2 REQD). SEE GENERAL NOTE "C" AT RIGHT.

SEAL FOR 3/4" STRAPPING (6 REQD, 1 PER STRAP). CRIMP EACH SEAL WITH TWO PAIR OF NOTCHES.

GENERAL NOTES

- THIS APPENDIX CANNOT STAND ALONE BUT MUST BE USED IN CONJUNCTION WITH THE BASIC UNITIZATION PROCEDURES DRAWING 19-48-4116-20PA1002. TO PRODUCE AN APPROVED UNIT LOAD, ALL PERTINENT PROCEDURES, SPECIFICATIONS AND CRITERIA SET FORTH WITHIN THE BASIC DRAWING WILL APPLY TO THE PROCEDURES DELINEATED IN THIS APPENDIX. ANY EXCEPTIONS TO THE BASIC PROCEDURES ARE SPECIFIED IN THIS APPENDIX.
- DIMENSIONS, CUBE AND WEIGHT OF A PALLET UNIT WILL VARY SLIGHTLY DEPENDING UPON THE ACTUAL DIMENSIONS OF THE BOXES AND THE WEIGHT OF THE SPECIFIC ITEM BEING UNITIZED.
- THE LOAD STRAPS WILL BE THREADED THROUGH THE STRAP SLOTS OF THE PALLET. LOAD STRAPS MUST BE TENSIONED AND SEALED PRIOR TO APPLICATION OF TIEDOWN STRAPS.
- INSTALL EACH TIEDOWN STRAP TO PASS UNDER THE DECK/STRINGER BOARDS OF THE PALLET AND TO BE LOCATED BETWEEN THE VERTICAL END CLEATS OF THE BOXES. TIEDOWN STRAPS WILL NOT BE APPLIED UNTIL THE LOAD STRAPS HAVE BEEN TENSIONED AND SEALED.
- THE FOLLOWING DARCOM DRAWINGS ARE APPLICABLE FOR OUTLOADING AND STORAGE OF THE ITEMS COVERED BY THIS APPENDIX.
 - CARLOADING ----- DRAWING 19-48-4115-5PA1002
 - TRUCKLOADING --- DRAWING 19-48-4117-11PA1003
 - STORAGE ----- DRAWING 19-48-4118-1-2-3-4-14-22PA1002
- FOR METHOD OF SECURING A STRAP CUTTER TO THE PALLET UNIT, SEE DARCOM DRAWING 19-48-4127-20P1000.
- IF ITEMS COVERED HEREIN ARE UNITIZED PRIOR TO ISSUANCE OF THIS APPENDIX, THE BOXES NEED NOT BE REUNITIZED SOLELY TO CONFORM TO THIS APPENDIX.
- THE UNITIZATION PROCEDURES DEPICTED HEREIN MAY ALSO BE USED FOR UNITIZING PHOTOFLASH CARTRIDGE WHEN IDENTIFIED BY A DIFFERENT NATIONAL STOCK NUMBER (NSN) THAN THOSE SHOWN ON THE TITLE PAGE, PROVIDED THE BOX PACK DOES NOT VARY FROM THOSE SHOWN HEREIN. THE EXPLOSIVE CLASSIFICATION OF OTHER ITEMS MAY BE DIFFERENT THAN THOSE SHOWN.

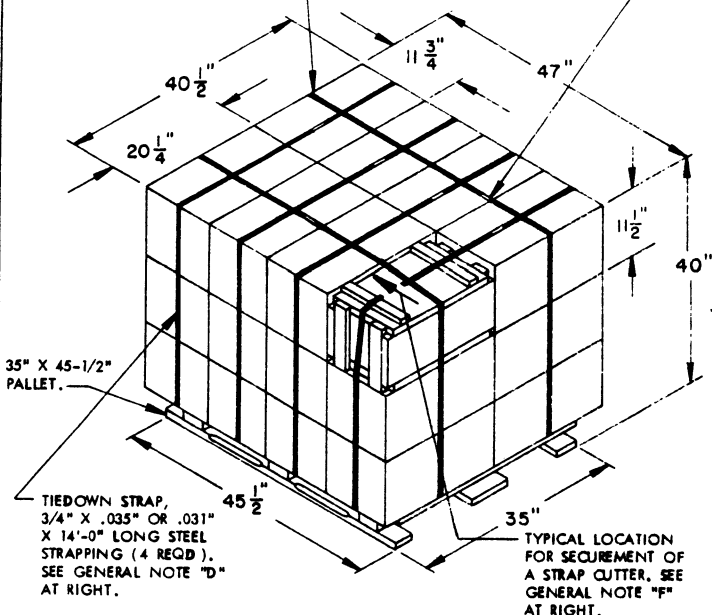

PALLET UNIT

SEE GENERAL NOTE "B" AT RIGHT.

24 BOXES OF CARTRIDGE, PHOTOFLASH (24 PER BOX) @ 75 LBS -- 1800 LBS (APPROX)
 DUNNAGE ----- 6 LBS
 PALLET ----- 65 LBS

TOTAL WEIGHT ----- 1871 LBS (APPROX)

CUBE ----- 44.1 CU FT (APPROX)

BILL OF MATERIAL

PALLET, 35" X 45-1/2"	1 REQD	65 LBS
STEEL STRAPPING, 3/4"	86 REQD	6 LBS
SEAL FOR 3/4" STRAPPING	6 REQD	NIL

TIE PIECE, 1" X 4" BY BOX WIDTH (2 REQD).
 NAIL TO LONGITUDINAL PIECES W/2-6d
 NAILS AT EACH END AND TO LATERAL
 PIECE W/2-6d NAILS.

VERTICAL PIECE, 2" X 4" X
 BOX HEIGHT MINUS 3/4" (4 REQD).

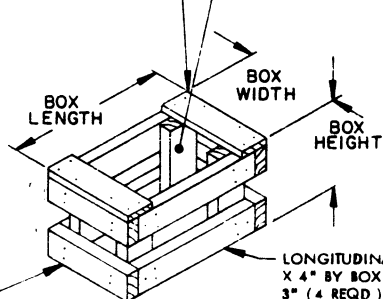

LATERAL PIECE, 2" X 4" X
 BOX WIDTH (4 REQD).
 NAIL TO VERTICAL PIECES
 W/2-10d NAILS AT EACH
 END.

LONGITUDINAL PIECE, 2"
 X 4" BY BOX LENGTH MINUS
 3" (4 REQD). NAIL TO
 VERTICAL PIECES W/3-10d
 NAILS AT EACH END.

FILLER ASSEMBLY

(FOR MINUS ONE BOX)