

APPENDIX 104

UNITIZATION PROCEDURES FOR BOXED AMMUNITION AND COMPONENTS ON 4-WAY ENTRY PALLETS

STARTER, FIRE, PACKED 500 PER WOODEN BOX,
UNITIZED 40 BOXES PER 40" X 48" PALLET;
APPROX BOX SIZE $21\frac{3}{8}$ " L X $10\frac{1}{2}$ " W X $8\frac{1}{4}$ " H

PALLET UNIT DATA						
ITEMS INCLUDED		HAZARD CLASSIFICATION ^①				WEIGHT
NSN	DODIC	DOT CLASS	CG CLASS	QD CLASS	COMP GROUP	(LBS)
1370-00 219-8566	L621	B	II-G	1.3	G	1,488

REVISIONS

REVISION NO. 1, DATED MAY 1984, CONSISTS OF:

ADDING ITEM BY NATIONAL STOCK NUMBER TO "PALLET UNIT DATA" CHART.

REVISION NO. 2, DATED JUNE 1986, CONSISTS OF:

DELETING ITEM BY NATIONAL STOCK NUMBER FROM "PALLET UNIT DATA" CHART.

REVISION NO. 3, DATED OCTOBER 1987, CONSISTS OF:

ADDING GENERAL NOTE "J".

NOTICE: THIS APPENDIX CANNOT STAND ALONE BUT MUST
BE USED IN CONJUNCTION WITH THE BASIC UNITIZATION
PROCEDURES DRAWING 19-48-4116-20PA1002.

① HAZARD CLASSIFICATION DATA CONTAINED IN THE ABOVE CHART IS FOR GUIDANCE AND INFORMATIONAL PURPOSES ONLY. VERIFICATION OF THE SPECIFIED DATA SHOULD BE MADE BY CONSULTING THE MOST RECENT JOINT HAZARD CLASSIFICATION SYSTEM LISTING OR OTHER APPROVED LISTING(S).

REVISIONS				DRAFTSMAN PJE	PROJ ENG RJB	MTR (R2) AJH (R3)	
NO.	DATE	BY	CHECKER	LOG ENGRG OFFICE			
1	MAY 84	WJE	RSH	APPROVED, U. S. ARMY ARMAMENT MATERIEL READINESS COMMAND			
2	JUN 86	WJE	J. A. Jackson	APPROVED BY ORDER OF COMMANDING GENERAL, U. S. ARMY MATERIEL DEVELOPMENT AND READINESS COMMAND (DARCOM)			
3	OCT 87	WJE	William F. Ernst	DARCOM AMMO CENTER			
U. S. ARMY DARCOM DRAWING				OCTOBER 1977			
				CLASS	DIVISION	DRAWING	FILE
				19	48	4116/104	20PA 1002

DO NOT SCALE

LOAD STRAP, 3/4" X .035" OR .031" X 16'-0" LONG STEEL STRAPPING (2 REQD).
SEE GENERAL NOTE "C" AT RIGHT.

SEAL FOR 3/4" STRAPPING (7 REQD, 1 PER STRAP). CRIMP EACH SEAL WITH TWO PAIR OF NOTCHES.

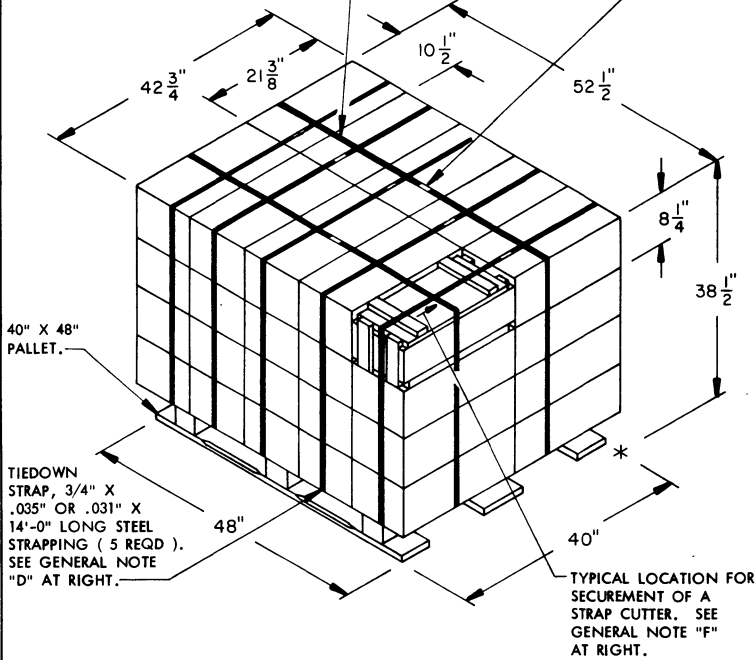

PALLET UNIT

SEE GENERAL NOTE "B" AT RIGHT.

40 BOXES OF FIRE STARTER (500 PER BOX) @ 35 LBS -----	1,400 LBS (APPROX)
DUNNAGE -----	8 LBS
PALLET -----	80 LBS
TOTAL WEIGHT -----	1,488 LBS (APPROX)
CUBE -----	50 CU FT (APPROX)

BILL OF MATERIAL

PALLET, 40" X 48" -----	1 REQD -----	80 LBS
STEEL STRAPPING, 3/4" -----	102' REQD -----	8 LBS
SEAL FOR 3/4" STRAPPING -----	7 REQD -----	NIL

TIE PIECE, 1" X 4" X BOX WIDTH (2 REQD).
NAIL TO LONGITUDINAL PIECES W/2-6d NAILS
AT EACH END AND TO LATERAL PIECE W/2-6d NAILS.

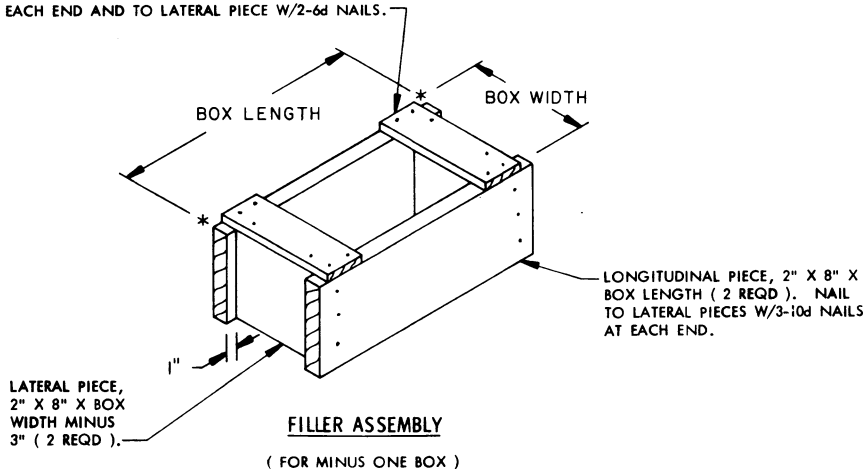

FILLER ASSEMBLY
(FOR MINUS ONE BOX)

GENERAL NOTES

- A. THIS APPENDIX CANNOT STAND ALONE BUT MUST BE USED IN CONJUNCTION WITH THE BASIC UNITIZATION PROCEDURES DRAWING 19-48-4116-20PA1002. TO PRODUCE AN APPROVED UNIT LOAD, ALL PERTINENT PROCEDURES, SPECIFICATIONS AND CRITERIA SET FORTH WITHIN THE BASIC DRAWING WILL APPLY TO THE PROCEDURES DELINEATED IN THIS APPENDIX. ANY EXCEPTIONS TO THE BASIC PROCEDURES ARE SPECIFIED IN THIS APPENDIX.
- B. DIMENSIONS, CUBE AND WEIGHT OF A PALLET UNIT WILL VARY SLIGHTLY DEPENDING UPON THE ACTUAL DIMENSIONS OF THE BOXES AND THE WEIGHT OF THE SPECIFIC ITEM BEING UNITIZED.
- C. THE LOAD STRAPS MAY BE THREADED THROUGH THE STRAP SLOT OF A PALLET OR PRE-POSITIONED ON THE PALLET DECK PRIOR TO PLACING BOXES ON THE PALLET. LOAD STRAPS MUST BE TENSIONED AND SEALED PRIOR TO APPLICATION OF TIEDOWN STRAPS.
- D. INSTALL EACH TIEDOWN STRAP TO PASS UNDER THE DECK/STRINGER BOARDS OF THE PALLET AND TO BE LOCATED BETWEEN THE VERTICAL END CLEATS OF THE BOXES. TIEDOWN STRAPS WILL NOT BE APPLIED UNTIL THE LOAD STRAPS HAVE BEEN TENSIONED AND SEALED.
- E. THE FOLLOWING AMC (DARCOM) DRAWINGS ARE APPLICABLE FOR OUT-LOADING AND STORAGE OF THE ITEMS COVERED BY THIS APPENDIX.
 - CARLOADING ----- DRAWING 19-48-4115-5PA1002
 - TRUCKLOADING ----- DRAWING 19-48-4117-11PA1003
 - STORAGE ----- DRAWING 19-48-4118-1-2-3-14-22PA1002
- F. FOR METHOD OF SECURING A STRAP CUTTER TO THE PALLET UNIT, SEE DARCOM DRAWING 19-48-4127-20P1000.
- G. IF ITEMS COVERED HEREIN ARE UNITIZED PRIOR TO ISSUANCE OF THIS APPENDIX, THE BOXES NEED NOT BE REUNITIZED SOLELY TO CONFORM TO THIS APPENDIX.
- H. THE UNITIZATION PROCEDURES DEPICTED HEREIN MAY ALSO BE USED FOR UNITIZING FIRE STARTERS WHEN IDENTIFIED BY DIFFERENT NATIONAL STOCK NUMBERS (NSN) THAN WHAT IS SHOWN ON THE TITLE PAGE, PROVIDED THE BOX PACK DOES NOT VARY FROM WHAT IS DELINEATED HEREIN. THE EXPLOSIVE CLASSIFICATION OF OTHER ITEMS MAY BE DIFFERENT THAN WHAT IS SHOWN.
- J. THE STYLE 1 PALLET DELINEATED IN THE DETAIL AT LEFT NEED NOT HAVE CHAMFERS OR STRAP SLOTS AS SPECIFIED WITHIN MILITARY SPECIFICATION MIL-P-15011 WHEN USED FOR THE UNITIZATION OF THE ITEMS COVERED BY THIS APPENDIX.