

APPENDIX 102C

UNITIZATION PROCEDURES FOR BOXED AMMUNITION AND COMPONENTS ON 4-WAY ENTRY PALLETS

RIOT CONTROL AGENT: CS (CAPSULES) 250
CAPSULES PER FIBERBOARD BOX, OVERPACKED
10 PER WOODEN BOX, UNITIZED 24 BOXES
PER 40" X 48" PALLET; APPROX BOX SIZE
20-1/2" L X 17" W X 11-1/4" H

NOTICE: THIS APPENDIX CANNOT STAND ALONE BUT MUST BE USED IN CONJUNCTION WITH
THE BASIC UNITIZATION PROCEDURES DRAWING 19-48-4116-20PA1002.

DISTRIBUTION STATEMENT A.

APPROVED FOR PUBLIC RELEASE;
DISTRIBUTION IS UNLIMITED.

| U.S. ARMY MATERIEL COMMAND DRAWING | | | |
|--|--|---|---------------------------------------|
| APPROVED, U.S. ARMY INDUSTRIAL OPERATIONS COMMAND <i>194</i> <i>David E Stackwich</i> AMSTA-AR-ESK AMSIO-TMJ | DRAFTSMAN | BETTY J. KUNDERT | |
| | ENGINEER | SANDRA M. SCHULTZ | |
| | SUPPLY ENGINEERING DIVISION | TRANSPORTATION ENGINEERING DIVISION | VALIDATION ENGINEERING DIVISION |
| | <i>J. J. Muchnik</i> | <i>W. Frenick</i> | <i>J. Keenan</i> |
| APPROVED BY ORDER OF COMMANDING GENERAL, U.S. ARMY MATERIEL COMMAND <i>Larry V. Dullecke</i> | LOGISTICS ENGINEERING OFFICE <i>William Ernst</i> | | |
| | NOVEMBER 1995 | | |
| U.S. ARMY DEFENSE AMMUNITION CENTER AND SCHOOL | CLASS | DIVISION | DRAWING |
| REVISION NO. 1 | AUGUST 1996 | 19 | 48 |
| SEE THE REVISION LISTING ON PAGE 2 | | 4116/ 102C | 20PA 1002 |

DO NOT SCALE

| PALLET UNIT DATA | | | | |
|------------------|-------|-----------------------------|------------|-------------------|
| ITEMS INCLUDED | | HAZARD CLASS AND DIVISION ● | | APPROX WEIGHT LBS |
| NSN | DODIC | OD CLASS | COMP GROUP | |
| 1365-00-690-8656 | K765 | 6.1 | - | 1,168 |

- HAZARD CLASSIFICATION DATA CONTAINED IN THE ABOVE CHART IS FOR GUIDANCE AND INFORMATIONAL PURPOSES ONLY. VERIFICATION OF THE SPECIFIED DATA SHOULD BE MADE BY CONSULTING THE MOST RECENT JOINT HAZARD CLASSIFICATION SYSTEM LISTING OR OTHER APPROVED LISTING(S).

REVISION

REVISION NO. 1, DATED AUGUST 1996, CONSISTS OF:

1. ADDING "OVERPACKED 10 PER WOODEN BOX" TO TITLE.

TIEDOWN STRAP, 3/4" X .035" OR .031" X 15'-5" LONG STEEL STRAPPING (3 REQD). SEE GENERAL NOTE "D" AT RIGHT.

SEAL FOR 3/4" STRAPPING (5 REQD, 1 PER STRAP). CRIMP EACH SEAL WITH TWO PAIR OF NOTCHES.

LOAD STRAP, 3/4" X .035" OR .031" X 17'-1" LONG STEEL STRAPPING (2 REQD). SEE GENERAL NOTE "C" AT RIGHT.

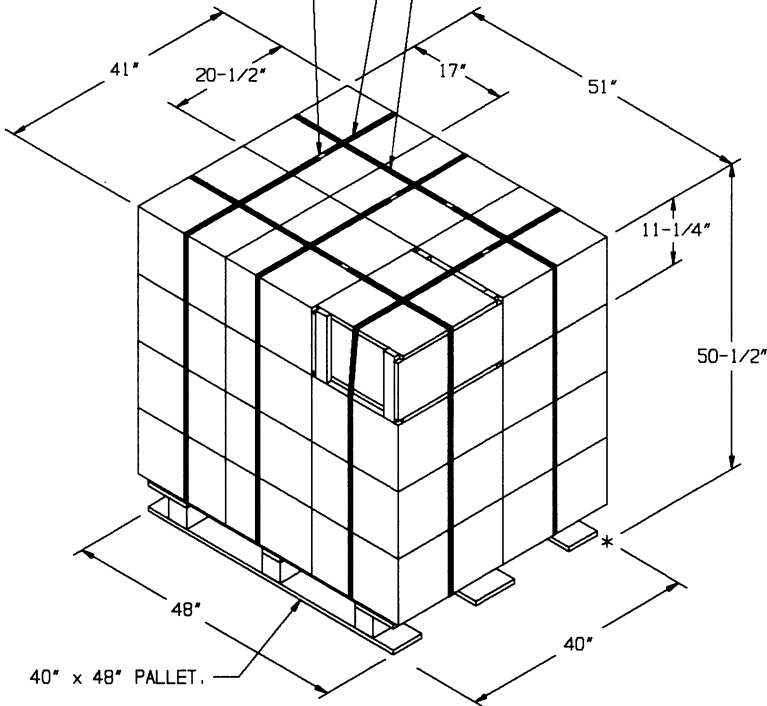

PALLET UNIT

SEE GENERAL NOTE "B" AT RIGHT

| | | |
|---|-----|----------------------------|
| 24 BOXES OF CAPSULES (2500 PER BOX) AT 45 LBS | --- | 1,080 LBS (APPROX) |
| DUNNAGE | --- | 8 LBS |
| PALLET | --- | 80 LBS |
| TOTAL WEIGHT | | 1,168 LBS (APPROX) |
| CUBE | | 61.1 CU FT (APPROX) |

BILL OF MATERIAL

| | | | | |
|-------------------------|-----|-------------|-----|----------|
| PALLET, 40" X 48" | --- | 1 REQD | --- | 80 LBS |
| STEEL STRAPPING, 3/4" | --- | 80.42' REQD | --- | 7.18 LBS |
| SEAL FOR 3/4" STRAPPING | --- | 6 REQD | --- | NIL |

GENERAL NOTES

- A. THIS APPENDIX CANNOT STAND ALONE BUT MUST BE USED IN CONJUNCTION WITH THE BASIC UNITIZATION PROCEDURES DRAWING 19-48-4116-20PA1002. TO PRODUCE AN APPROVED UNIT LOAD, ALL PERTINENT PROCEDURES, SPECIFICATIONS AND CRITERIA SET FORTH WITHIN THE BASIC DRAWING WILL APPLY TO THE PROCEDURES DELINEATED IN THIS APPENDIX. ANY EXCEPTIONS TO THE BASIC PROCEDURES ARE SPECIFIED IN THIS APPENDIX.
- B. DIMENSIONS, CUBE AND WEIGHT OF A PALLET UNIT WILL VARY SLIGHTLY DEPENDING UPON THE ACTUAL DIMENSIONS OF THE BOXES AND THE WEIGHT OF THE SPECIFIC ITEM BEING UNITIZED.
- C. THE LOAD STRAPS MAY BE THREADED THROUGH THE STRAP SLOTS OF A PALLET OR PRE-POSITIONED ON THE PALLET DECK PRIOR TO PLACING BOXES ON THE PALLET. LOAD STRAPS MUST BE TENSIONED AND SEALED PRIOR TO APPLICATION OF TIEDOWN STRAPS.
- D. INSTALL EACH TIEDOWN STRAP TO PASS UNDER THE DECK BOARDS OF THE PALLET AND TO BE LOCATED AS SHOWN. TIEDOWN STRAPS WILL NOT BE APPLIED UNTIL THE LOAD STRAPS HAVE BEEN TENSIONED AND SEALED.
- E. THE FOLLOWING AMC DRAWINGS ARE APPLICABLE FOR OUTLOADING AND STORAGE OF THE ITEMS COVERED BY THIS APPENDIX.
 - CARLOADING - - - - 19-48-4115-5PA1002
 - TRUCKLOADING - - - - 19-48-4117-11PA1003
 - STORAGE - - - - - 19-48-4118-1-2-3-4-14-22PA1002
 - END OPENING ISO
 - CONTAINER - - - - 19-48-4153-15PA1002
 - MILVAN - - - - - 19-48-4166-15PA1003
 - SIDE OPENING ISO
 - CONTAINER - - - - 19-48-4267-15PA1009
- F. IF ITEMS COVERED HEREIN ARE UNITIZED PRIOR TO ISSUANCE OF THIS APPENDIX, THE BOXES NEED NOT BE REUNITIZED SOLELY TO CONFORM TO THIS APPENDIX.
- G. THE UNITIZATION PROCEDURES DEPICTED HEREIN MAY ALSO BE USED FOR UNITIZING CAPSULES WHEN IDENTIFIED BY DIFFERENT NATIONAL STOCK NUMBERS (NSN) THAN WHAT IS SHOWN ON PAGE 2, PROVIDED THE BOX PACK DOES NOT VARY FROM WHAT IS DELINEATED HEREIN. THE EXPLOSIVE CLASSIFICATION OF OTHER ITEMS MAY BE DIFFERENT THAN WHAT IS SHOWN.
- H. THE STYLE 1 PALLET DELINEATED IN THE DETAIL AT LEFT NEED NOT HAVE CHAMFERS OR STRAP SLOTS AS SPECIFIED WITHIN MILITARY SPECIFICATION MIL-P-15011 WHEN USED FOR THE UNITIZATION OF ITEMS COVERED BY THIS APPENDIX.

VERTICAL PIECE, 2" X 4" X BOX HEIGHT MINUS 3/4" (4 REQD).

TIE PIECE, 1" X 4" X BOX WIDTH (2 REQD). NAIL TO LONGITUDINAL PIECES W/2-6d NAILS AT EACH END AND TO LATERAL PIECE W/1-6d NAIL.

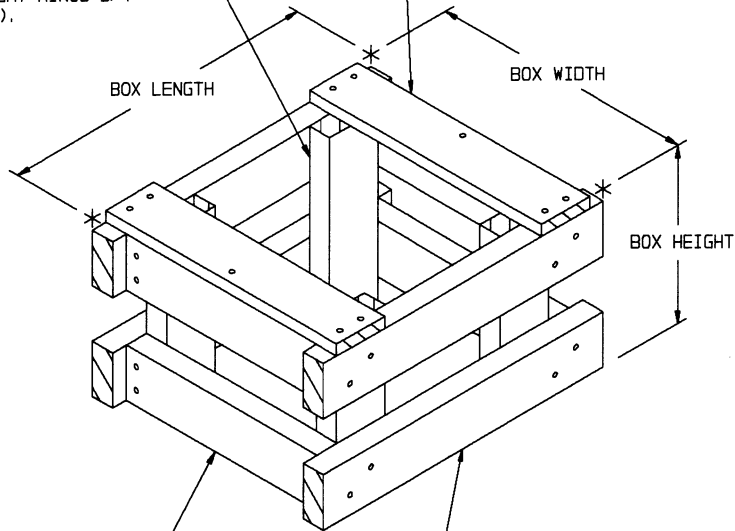

LATERAL PIECE, 2" X 4" X BOX WIDTH MINUS 3" (4 REQD). NAIL TO VERTICAL PIECES W/2-10d NAILS AT EACH END.

LONGITUDINAL PIECE, 2" X 4" X BOX LENGTH (4 REQD). NAIL TO VERTICAL PIECES W/2-10d NAILS AT EACH END.

FILLER ASSEMBLY
(FOR MINUS ONE BOX)