

APPENDIX 102A

UNITIZATION PROCEDURES FOR BOXED AMMUNITION AND COMPONENTS ON 4-WAY ENTRY PALLETS

RIOT CONTROL AGENT, ABC, PACKED 5 PER
WOODEN BOX, UNITIZED 8 BOXES PER 40" X
48" PALLET, APPROX BOX SIZE 37-1/4" L
X 13" W X 19-3/4" H

NOTICE: THIS APPENDIX CANNOT STAND ALONE BUT MUST BE USED IN CONJUNCTION WITH
THE BASIC UNITIZATION PROCEDURES DRAWING 19-48-4116-20PA1002.

U. S. ARMY MATERIEL COMMAND DRAWING			
APPROVED, U.S. ARMY ARMAMENT, MUNITIONS AND CHEMICAL COMMAND <i>David A. Pickens</i> <i>Timothy Fore</i> SMCAR-ESK AMSMC-TMJ/T	DRAFTSMAN BETTY J. KUNDERT ENGINEER SANDRA M. SCHULTZ		
APPROVED BY ORDER OF COMMANDING GENERAL, U.S. ARMY MATERIEL COMMAND <i>William F Ernst</i> U.S. ARMY DEFENSE AMMUNITION CENTER AND SCHOOL	SUPPLY ENGINEERING DIVISION <i>J. J. Michik</i>	TRANSPORTATION ENGINEERING DIVISION <i>W. Ernie</i>	VALIDATION ENGINEERING DIVISION <i>J. Wash</i>
		LOGISTICS ENGINEERING OFFICE <i>William F Ernst</i> FEBRUARY 1981	
	CLASS	DIVISION	DRAWING
REVISION NO. 2	19	48	4116/ 102A
SEE THE REVISION LISTING ON PAGE 2			20PA 1002

DO NOT SCALE

PALLET UNIT DATA				
ITEMS INCLUDED		HAZARD CLASS AND DIVISION ●		APPROX WEIGHT LBS
NSN	DDIC	OD CLASS	COMP GROUP	
1365-00-926-1914	K768	6.1	G	499
00-935-6016	K766	6.1	G	564

- HAZARD CLASSIFICATION DATA CONTAINED IN THE ABOVE CHART IS FOR GUIDANCE AND INFORMATIONAL PURPOSES ONLY. VERIFICATION OF THE SPECIFIED DATA SHOULD BE MADE BY CONSULTING THE MOST RECENT JOINT HAZARD CLASSIFICATION SYSTEM LISTING OR OTHER APPROVED LISTING(S).

REVISION

REVISION NO. 1, DATED NOVEMBER 1984,
CONSISTS OF:

1. CHANGING BOX DIMENSIONS.
2. UPDATING UNITIZATION PROCEDURES TO SATISFY CHANGED BOX DIMENSIONS.

REVISION NO. 2, DATED
CONSISTS OF:

1. CHANGING BOX ORIENTATION ON PALLET.

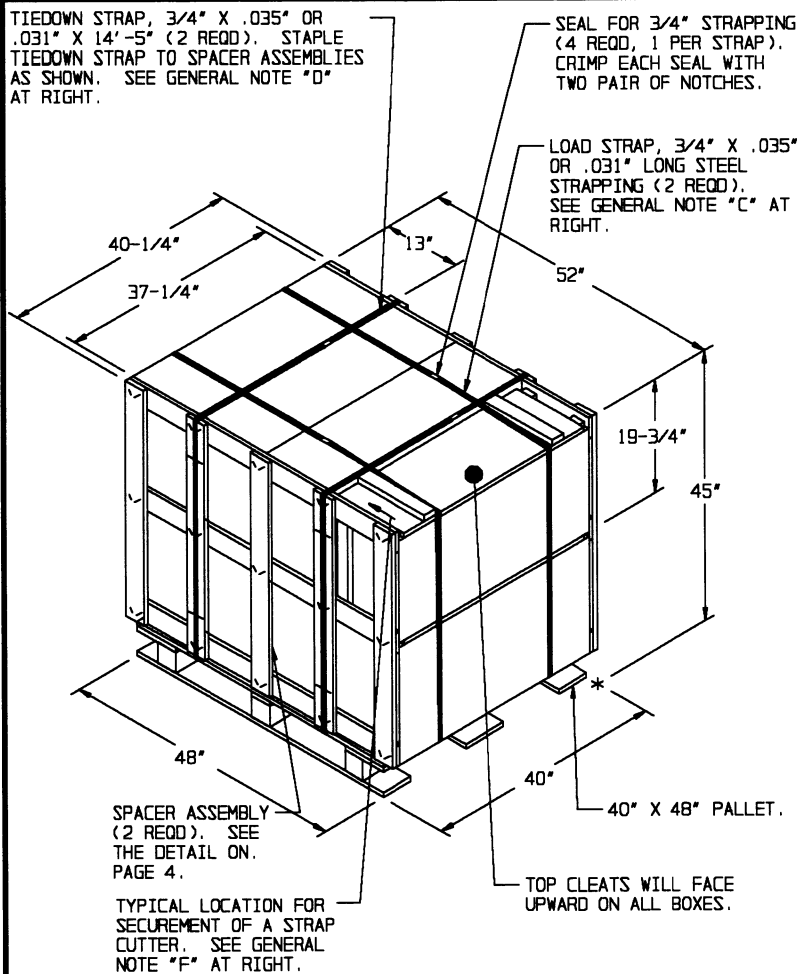

GENERAL NOTES

- A. THIS APPENDIX CANNOT STAND ALONE BUT MUST BE USED IN CONJUNCTION WITH THE BASIC UNITIZATION PROCEDURES DRAWING 19-48-4116-20PA1002. TO PRODUCE AN APPROVED UNIT LOAD, ALL PERTINENT PROCEDURES, SPECIFICATIONS AND CRITERIA SET FORTH WITHIN THE BASIC DRAWING WILL APPLY TO THE PROCEDURES DELINEATED IN THIS APPENDIX. ANY EXCEPTIONS TO THE BASIC PROCEDURES ARE SPECIFIED IN THIS APPENDIX.
- B. DIMENSIONS, CUBE AND WEIGHT OF A PALLET UNIT WILL VARY SLIGHTLY DEPENDING UPON THE ACTUAL DIMENSIONS OF THE BOXES AND THE WEIGHT OF THE SPECIFIC ITEM BEING UNITIZED.
- C. THE LOAD STRAPS MAY BE THREADED THROUGH THE STRAP SLOTS OF A PALLET OR PRE-POSITIONED ON THE PALLET DECK PRIOR TO PLACING BOXES ON THE PALLET. LOAD STRAPS MUST BE TENSIONED AND SEALED PRIOR TO APPLICATION OF TIEDOWN STRAPS.
- D. INSTALL EACH TIEDOWN STRAP TO PASS UNDER THE DECK BOARDS OF THE PALLET AND TO BE LOCATED AS SHOWN. TIEDOWN STRAPS WILL NOT BE APPLIED UNTIL THE LOAD STRAPS HAVE BEEN TENSIONED AND SEALED.
- E. THE FOLLOWING AMC DRAWINGS ARE APPLICABLE FOR OUTLOADING AND STORAGE OF THE ITEMS COVERED BY THIS APPENDIX.
 - CARLOADING - - - - 19-48-4115-5PA1002
 - TRUCKLOADING - - - - 19-48-4117-11PA1003
 - STORAGE - - - - - 19-48-4118-1-2-3-4-14-22PA1002
 - COMMERCIAL CONTAINER - - - - 19-48-4153-15PA1002
 - MILVAN - - - - - 19-48-4166-15PA1003
 - SIDE OPENING COMMERCIAL CONTAINER - - - - 19-48-4267-15PA1009
- F. FOR METHOD OF SECURING A STRAP CUTTER TO THE PALLET UNIT, SEE AMC DRAWING 19-48-4127-20P1000.
- G. IF ITEMS COVERED HEREIN ARE UNITIZED PRIOR TO ISSUANCE OF THIS APPENDIX, THE BOXES NEED NOT BE REUNITIZED SOLELY TO CONFORM TO THIS APPENDIX.
- H. THE UNITIZATION PROCEDURES DEPICTED HEREIN MAY ALSO BE USED FOR UNITIZING RIOT CONTROL AGENTS WHEN IDENTIFIED BY DIFFERENT NATIONAL STOCK NUMBERS (NSN) THAN WHAT IS SHOWN ON PAGE 2, PROVIDED THE BOX PACK DOES NOT VARY FROM WHAT IS DELINEATED HEREIN. THE EXPLOSIVE CLASSIFICATION OF OTHER ITEMS MAY BE DIFFERENT THAN WHAT IS SHOWN.
- J. THE STYLE 1 PALLET DELINEATED IN THE DETAIL AT LEFT NEED NOT HAVE CHAMFERS OR STRAP SLOTS AS SPECIFIED WITHIN MILITARY SPECIFICATION MIL-P-15011 WHEN USED FOR THE UNITIZATION OF ITEMS COVERED BY THIS APPENDIX.

PALLET UNIT

SEE GENERAL NOTE "B" AT RIGHT.

8 BOXES OF RIOT CONTROL AGENTS (3 PER BOX) AT 55 LBS	---	440 LBS (APPROX)
DUNNAGE	---	44 LBS
PALLET	---	80 LBS
TOTAL WEIGHT	---	564 LBS (APPROX)
CUBE	---	54.5 CU FT (APPROX)

BILL OF MATERIAL		
LUMBER	LINEAR FEET	BOARD FEET
1" X 4"	58.90	19.64
NAILS	NO. REQD	POUNDS
6d (2")	60	0.35
PALLET, 40" X 48"	1 REQD	80 LBS
STEEL STRAPPING, 3/4"	61.50 REQD	4.39 LBS
SEAL FOR 3/4" STRAPPING	4 REQD	NIL
STAPLE, 15/16" X 3/4"	8 REQD	NIL

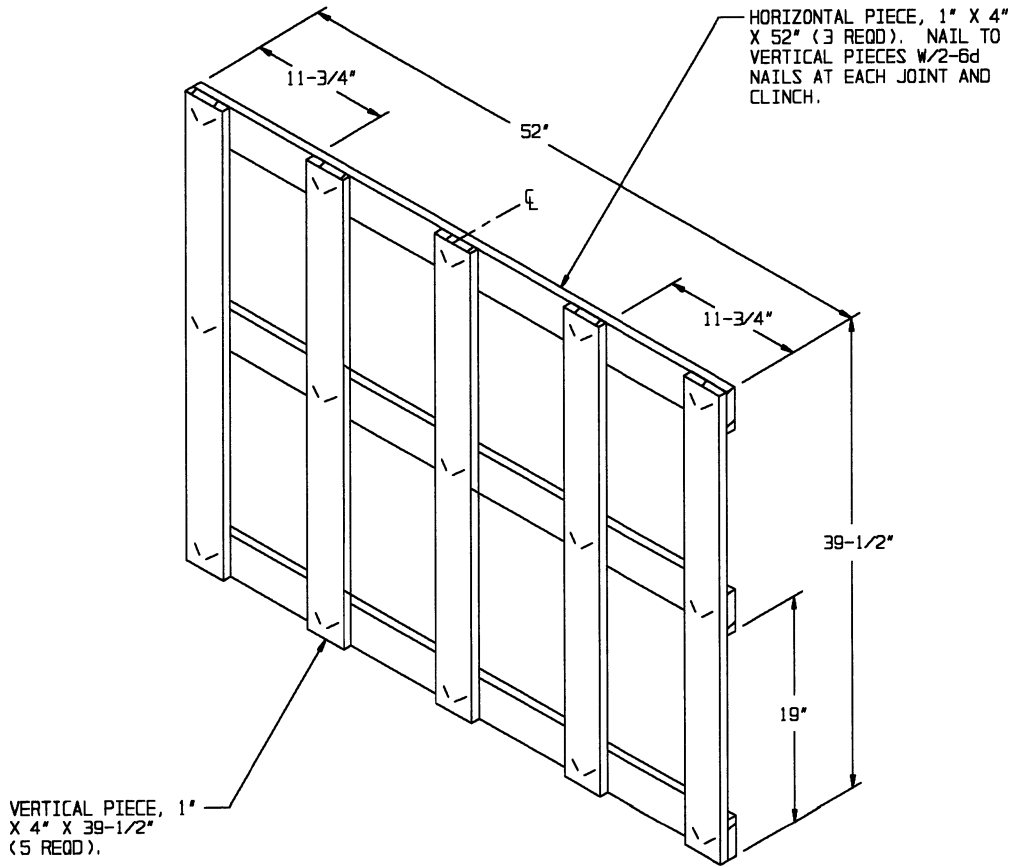

SPACER ASSEMBLY
(2 REQD)

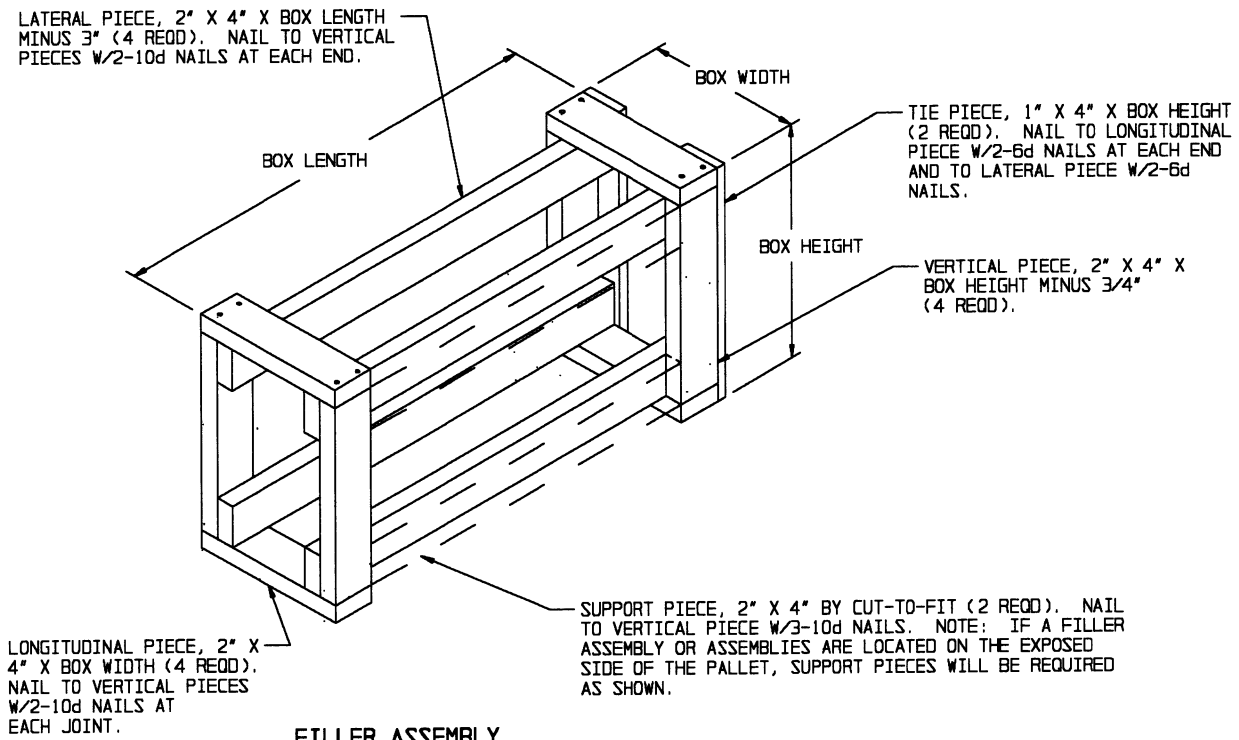

FILLER ASSEMBLY
(FOR MINUS ONE BOX)