

APPENDIX 102

UNITIZATION PROCEDURES FOR BOXED AMMUNITION AND COMPONENTS ON 4-WAY ENTRY PALLETS

DISPERSER AND RIOT CONTROL AGENT, CR, M36,
PACKED 12 PER WOODEN BOX, UNITIZED 50 BOXES
PER 35" X 45 1/2" PALLET; APPROX BOX SIZE
9" L X 7 1/2" W X 9" H

PALLET UNIT DATA						
ITEMS INCLUDED		HAZARD CLASSIFICATION ^①				WEIGHT (LBS)
NSN	DODIC	DOT CLASS	CG CLASS	QD CLASS	COMP GROUP	
1365-01-147-4613	K532	IR	XI-B	1.4	G	481

^① HAZARD CLASSIFICATION DATA CONTAINED IN THE ABOVE CHART IS FOR GUIDANCE AND INFORMATIONAL PURPOSES ONLY. VERIFICATION OF THE SPECIFIED DATA SHOULD BE MADE BY CONSULTING THE MOST RECENT JOINT HAZARD CLASSIFICATION SYSTEM LISTING OR OTHER APPROVED LISTING(S).

NOTICE: THIS APPENDIX CANNOT STAND ALONE BUT MUST BE USED IN CONJUNCTION WITH THE BASIC UNITIZATION PROCEDURES DRAWING 19-48-4116-20PA1002.

REVISION

REVISION NO. 1, DATED JANUARY 1984, CONSISTS OF:

1. ADDING ITEM BY NATIONAL STOCK NUMBER TO "PALLET UNIT DATA" CHART.
2. ADDING HAZARD CLASSIFICATION INFORMATION NOTE.

DO NOT SCALE

REVISIONS		DRAFTSMAN WRF/HT	PROJ ENG WRF/HT
1	JAN 84	<i>[Signature]</i> CHKR C/G	<i>[Signature]</i> LOG ENGRG OFFICE W. F. Orndt
		APPROVED BY ORDER OF COMMANDING GENERAL U. S. ARMY MATERIEL DEVELOPMENT AND READINESS COMMAND (DARCOM)	
		U. S. ARMY DARCUM DRAWING	
		MARCH 1983	
		CLASS	DIVISION
		19	48
		DRAWING	FILE
		4116/ 102	20PA 1002

SEAL FOR 3/4" STRAPPING
(7 REQ'D, 1 PER STRAP).
CRIMP EACH SEAL WITH TWO
PAIR OF NOTCHES.

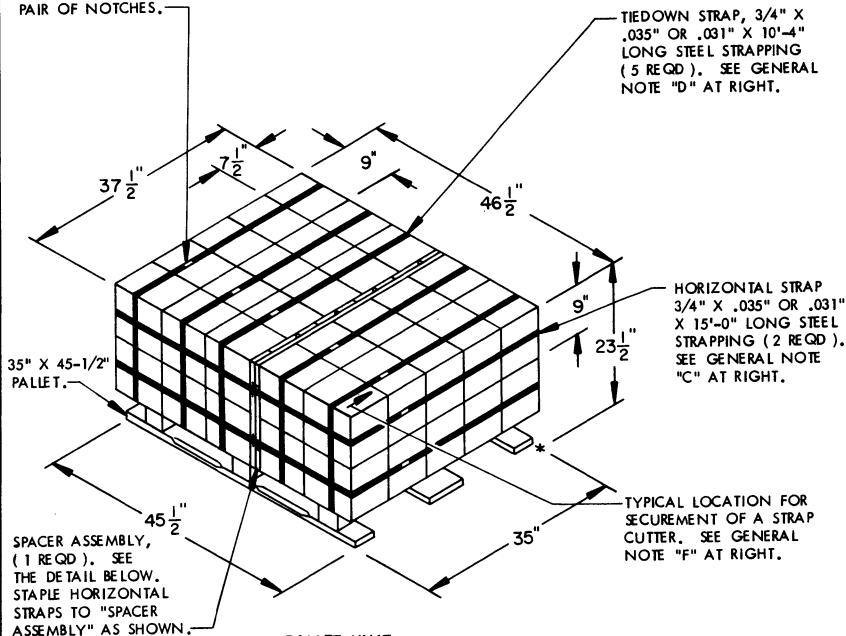

PALLET UNIT

SEE GENERAL NOTE "B" AT RIGHT.

50 BOXES OF DISPENSERS (12 PER BOX) @ 8 LBS ----- 400 LBS (APPROX)
DUNNAGE ----- 16 LBS
PALLET ----- 65 LBS

TOTAL WEIGHT ----- 481 LBS (APPROX)
CUBE ----- 23.7 CU FT (APPROX)

GENERAL NOTES

- A. THIS APPENDIX CANNOT STAND ALONE BUT MUST BE USED IN CONJUNCTION WITH THE BASIC UNITIZATION PROCEDURES DRAWING 19-48-4116-20PA1002. TO PRODUCE AN APPROVED UNIT LOAD, ALL PERTINENT PROCEDURES, SPECIFICATIONS AND CRITERIA SET FORTH WITHIN THE BASIC DRAWING WILL APPLY TO THE PROCEDURES DELINEATED IN THIS APPENDIX. ANY EXCEPTIONS TO THE BASIC PROCEDURES ARE SPECIFIED IN THIS APPENDIX.
- B. DIMENSIONS, CUBE AND WEIGHT OF A PALLET UNIT WILL VARY SLIGHTLY DEPENDING UPON THE ACTUAL DIMENSIONS OF THE BOXES AND THE WEIGHT OF THE SPECIFIC ITEM BEING UNITIZED.
- C. INSTALL EACH HORIZONTAL STRAP TO ENCIRCLE A LAYER OF BOXES ON THE PALLET. HORIZONTAL STRAPS MUST BE TENSIONED AND SEALED PRIOR TO APPLICATION OF TIEDOWN STRAPS.
- D. INSTALL EACH TIEDOWN STRAP TO PASS UNDER THE DECK/ STRINGER BOARDS OF THE PALLET AND TO BE LOCATED AS SHOWN. TIEDOWN STRAPS WILL NOT BE APPLIED UNTIL THE HORIZONTAL STRAPS HAVE BEEN TENSIONED AND SEALED.
- E. THE FOLLOWING DARCOM DRAWINGS ARE APPLICABLE FOR OUTLOADING AND STORAGE OF THE ITEMS COVERED BY THIS APPENDIX.
CARLOADING ----- DRAWING 19-48-4115-5PA1002
TRUCKLOADING -- DRAWING 19-48-4117-11PA1003
STORAGE ----- DRAWING 19-48-4118-1-2-3-4-14-22PA1002
- F. FOR METHOD OF SECURING A STRAP CUTTER TO THE PALLET UNIT, SEE DARCOM DRAWING 19-48-4127-20P1000.
- G. IF ITEMS COVERED HEREIN ARE UNITIZED PRIOR TO ISSUANCE OF THIS APPENDIX, THE BOXES NEED NOT BE REUNITIZED SOLELY TO CONFORM TO THIS APPENDIX.
- H. THE UNITIZATION PROCEDURES DEPICTED HEREIN MAY ALSO BE USED FOR UNITIZING DISPENSER AND RIOT CONTROL AGENTS WHEN IDENTIFIED BY DIFFERENT NATIONAL STOCK NUMBERS (NSN) THAN WHAT IS SHOWN ON THE TITLE PAGE, PROVIDING THE BOX PACK DOES NOT VARY FROM WHAT IS DELINEATED HEREIN. THE EXPLOSIVE CLASSIFICATION OF OTHER ITEMS MAY BE DIFFERENT THAN WHAT IS SHOWN.

BILL OF MATERIAL

LUMBER	LINEAR FEET	BOARD FEET
1" X 4"	13.75	4.58
NAILS	NO. REQ'D	POUNDS
6d (2")	20	0.12
PALLET, 35" X 45-1/2" ----- 1 REQ'D ----- 65 LBS		
STEEL STRAPPING, 3/4" ----- 81.67 REQ'D ----- 5.83 LBS		
SEAL FOR 3/4" STRAPPING ----- 7 REQ'D ----- NIL		
STAPLE, 15/16" X 3/4" ----- 4 REQ'D ----- NIL		

LATERAL PIECE,
2" X 10" (RIPPED TO BOX
HEIGHT) BY BOX WIDTH MINUS 3"
(2 REQ'D). NAIL TO SUPPORT PIECES
W/3-10d NAILS AT EACH END.

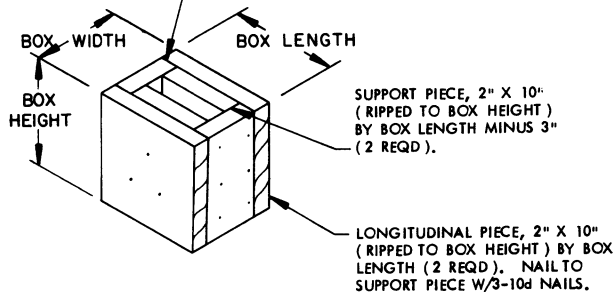

FILLER ASSEMBLY

(FOR MINUS ONE BOX)

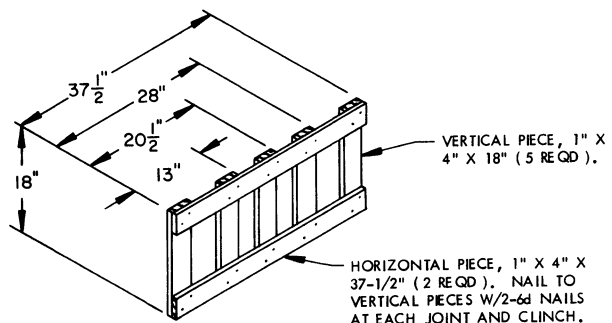

SPACER ASSEMBLY

(ONE REQ'D)