

APPENDIX 100A

UNITIZATION PROCEDURES FOR BOXED AMMUNITION AND COMPONENTS ON 4-WAY ENTRY PALLETS

FUZE, SMOKE POT, PACKED 300 PER WIREBOUND OR
WOODEN BOX, UNITIZED 27 WIREBOUND BOXES PER
42" X 53" PALLET (UNIT LOAD A) OR 24 WOODEN BOXES
PER 40" X 48" PALLET (UNIT LOAD B); APPROX
WIREBOUND BOX SIZE 17 $\frac{1}{4}$ " L X 14 $\frac{1}{8}$ " W X 9 $\frac{1}{4}$ " H;
APPROX WOODEN BOX SIZE 18" L X 14 $\frac{3}{4}$ " W X 10 $\frac{5}{8}$ " H

PALLET UNIT DATA							
ITEMS INCLUDED		HAZARD CLASSIFICATION				WEIGHT (LBS)	
NSN	DODIC	DOT CLASS	CG CLASS	QD CLASS	COMP GROUP	UNIT A	UNIT B
1365-00-025-3280	K886	C	III	(04) 1, 2	B	2, 245	2, 078

NOTICE: THIS APPENDIX CANNOT STAND ALONE BUT MUST BE USED IN CONJUNCTION WITH THE BASIC UNITIZATION PROCEDURES DRAWING 19-48-4116-20PA1002.

REVISION

REVISION NO. 1, DATED OCTOBER 1982, CONSISTS OF:

1. CHANGING WOODEN BOX DIMENSIONS.
2. ADDING PROCEDURES FOR WIREBOUND BOXES.
3. CHANGING PROCEDURES TO CONFORM TO 1. AND 2. ABOVE.

DO NOT SCALE

REVISIONS				DRAFTSMAN	PROJ ENG
1	OCT 82	<i>W</i>	<i>W</i>	<i>W</i>	<i>W</i>
				CHECKER <i>RSW</i>	LOG ENGRG OFFICE <i>John Boyd</i>
				APPROVED, U. S. ARMY ARMAMENT MATERIEL READINESS COMMAND	
				<i>John L. Boyd Jr.</i>	
				DARRAR - MAD DARRAR - TMD	
				APPROVED BY ORDER OF COMMANDING GENERAL, U. S. ARMY MATERIEL DEVELOPMENT AND READINESS COMMAND (DARCOM)	
				<i>John L. Boyd Jr.</i>	
				U. S. ARMY DEFENSE AMMUNITION CENTER AND SCHOOL	
				JULY 1980	
				CLASS	DIVISION
				DRAWING	FILE
				19	48
				4116/ 100A	20PA 1002

GENERAL NOTES

- A. THIS PAGE OF THIS APPENDIX CANNOT STAND ALONE BUT MUST BE USED IN CONJUNCTION WITH THE BASIC UNITIZATION PROCEDURES DRAWING 19-48-4116-20PA1002 TO PRODUCE AN APPROVED UNIT LOAD, ALL PERTINENT PROCEDURES, SPECIFICATIONS AND CRITERIA SET FORTH WITHIN THE BASIC DRAWING WILL APPLY TO THE PROCEDURES DELINEATED IN THIS APPENDIX. ANY EXCEPTIONS TO THE BASIC PROCEDURES ARE SPECIFIED.
- B. DIMENSIONS, CUBE AND WEIGHT OF A PALLET UNIT WILL VARY SLIGHTLY DEPENDING UPON THE ACTUAL DIMENSIONS OF THE BOXES AND THE WEIGHT OF THE SPECIFIC ITEM BEING UNITIZED.
- C. THE LOAD STRAPS MUST BE PRE-POSITIONED ON THE PALLET DECK PRIOR TO PLACING BOXES ON THE PALLET. NOTE THAT THE STRAPS WILL BE LOCATED AS DIMENSIONED. LOAD STRAPS MUST BE TENSIONED AND SEALED PRIOR TO APPLICATION OF TIEDOWN STRAPS.
- D. INSTALL EACH TIEDOWN STRAP TO PASS UNDER THE TOP DECK BOARDS OF THE PALLET AND TO BE LOCATED AS DIMENSIONED. TIEDOWN STRAPS WILL NOT BE APPLIED UNTIL THE LOAD STRAPS HAVE BEEN TENSIONED AND SEALED.
- E. THE FOLLOWING DARCOM DRAWINGS ARE APPLICABLE FOR UNLOADING AND STORAGE OF THE ITEMS COVERED BY THIS APPENDIX.
 CARLOADING-----DRAWING 19-48-4115-5PA1002
 TRUCKLOADING ----DRAWING 19-48-4117-11PA1003
 STORAGE-----DRAWING 19-48-4118-1-2-3-4-14-22PA1002
- F. FOR METHOD OF SECURING A STRAP CUTTER TO THE PALLET UNIT, SEE DARCOM DRAWING 19-48-4127-20P-1000.
- G. IF ITEMS COVERED HEREIN ARE UNITIZED PRIOR TO ISSUANCE OF THIS APPENDIX, THE BOXES NEED NOT BE REUNITIZED SOLELY TO CONFORM TO THIS APPENDIX.
- H. THE UNITIZATION PROCEDURES DEPICTED HEREIN MAY ALSO BE USED FOR UNITIZING SMOKE POT FUZES WHEN IDENTIFIED BY DIFFERENT NATIONAL STOCK NUMBERS (NSN) THAN WHAT IS SHOWN ON THE TITLE PAGE, PROVIDED THE BOX PACK DOES NOT VARY FROM WHAT IS DELINEATED HEREIN. THE EXPLOSIVE CLASSIFICATION OF OTHER ITEMS MAY BE DIFFERENT THAN WHAT IS SHOWN.

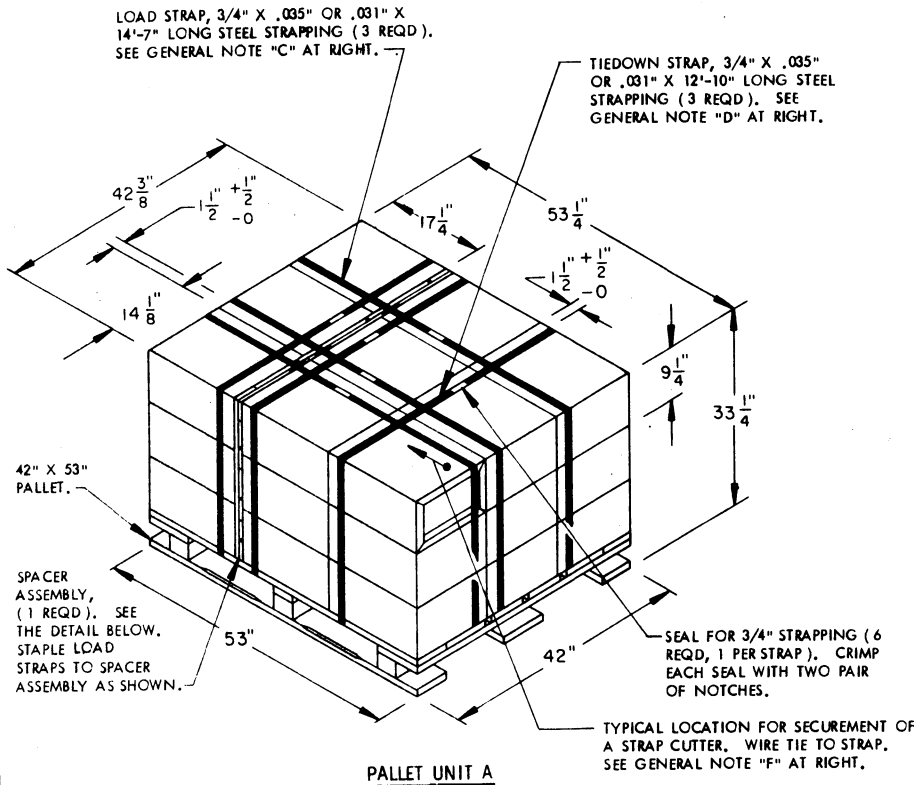

PALLET UNIT A

SEE GENERAL NOTE "B" AT RIGHT.

27 BOXES OF FUZES (300 PER BOX) @ 79 LBS-----	2,133 LBS (APPROX)
DUNNAGE-----	22 LBS
PALLET-----	90 LBS
TOTAL WEIGHT-----	2,245 LBS (APPROX)
CUBE-----	43.4 CU FT. (APPROX)

BILL OF MATERIAL (UNIT A)		
LUMBER	LINEAR FEET	BOARD FEET
1" X 4"	23.25	7.75
NAILS	NO. REQD	POUNDS
6d (2")	32	0.19
PALLET, 42" X 53"-----1 REQD-----90 LBS		
STEEL STRAPPING, 3/4"-----82.25' REQD-----5.87 LBS		
SEAL FOR 3/4" STRAPPING-----6 REQD-----NIL		
STAPLE, 15/16" X 3/4"-----3 REQD-----NIL		

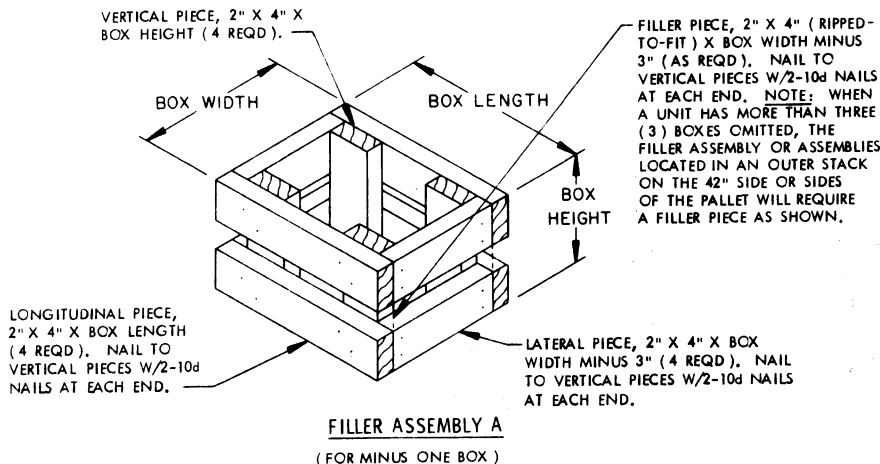

FILLER ASSEMBLY A
(FOR MINUS ONE BOX)

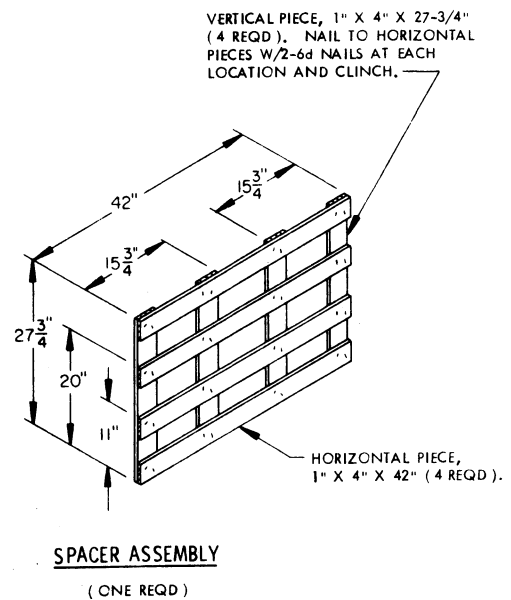

SPACER ASSEMBLY
(ONE REQD)

GENERAL NOTES

- A. THIS PAGE OF THIS APPENDIX CANNOT STAND ALONE BUT MUST BE USED IN CONJUNCTION WITH THE BASIC UNITIZATION PROCEDURES DRAWING 19-48-4116-20PA1002. TO PRODUCE AN APPROVED UNIT LOAD, ALL PERTINENT PROCEDURES, SPECIFICATIONS AND CRITERIA SET FORTH WITHIN THE BASIC DRAWING WILL APPLY TO THE PROCEDURES DELINEATED IN THIS APPENDIX. ANY EXCEPTIONS TO THE BASIC PROCEDURES ARE SPECIFIED.
- B. DIMENSIONS, CUBE AND WEIGHT OF A PALLET UNIT WILL VARY SLIGHTLY DEPENDING UPON THE ACTUAL DIMENSIONS OF THE BOXES AND THE WEIGHT OF THE SPECIFIC ITEM BEING UNITIZED.
- C. INSTALL EACH HORIZONTAL STRAP TO ENCIRCLE A LAYER OF BOXES ON THE PALLET. HORIZONTAL STRAPS MUST BE TENSIONED AND SEALED PRIOR TO APPLICATION OF TIEDOWN STRAPS.
- D. INSTALL EACH TIEDOWN STRAP TO PASS UNDER THE TOP DECK BOARDS OF THE PALLET AND TO BE LOCATED AS SHOWN. TIEDOWN STRAPS WILL NOT BE APPLIED UNTIL THE HORIZONTAL STRAPS HAVE BEEN TENSIONED AND SEALED.
- E. THE FOLLOWING DARCOM DRAWINGS ARE APPLICABLE FOR ODLADING AND STORAGE OF THE ITEMS COVERED BY THIS APPENDIX.
 CARLOADING ----DRAWING 19-48-4115-5PA1002
 TRUCKLOADING --DRAWING 19-48-4117-11PA1003
 STORAGE-----DRAWING 19-48-4118-1-2-3-4-14-22PA1002
- F. FOR METHOD OF SECURING A STRAP CUTTER TO THE PALLET UNIT, SEE DARCOM DRAWING 19-48-4127-20P1000.
- G. IF ITEMS COVERED HEREIN ARE UNITIZED PRIOR TO ISSUANCE OF THIS APPENDIX, THE BOXES NEED NOT BE REUNITIZED SOLELY TO CONFORM TO THIS APPENDIX.
- H. THE UNITIZATION PROCEDURES DEPICTED HEREIN MAY ALSO BE USED FOR UNITIZING SMOKE POT FUZES WHEN IDENTIFIED BY DIFFERENT NATIONAL STOCK NUMBERS (NSN) THAN WHAT IS SHOWN ON THE TITLE PAGE, PROVIDED THE BOX PACK DOES NOT VARY FROM WHAT IS DELINEATED HEREIN. THE EXPLOSIVE CLASSIFICATION OF OTHER ITEMS MAY BE DIFFERENT THAN WHAT IS SHOWN.

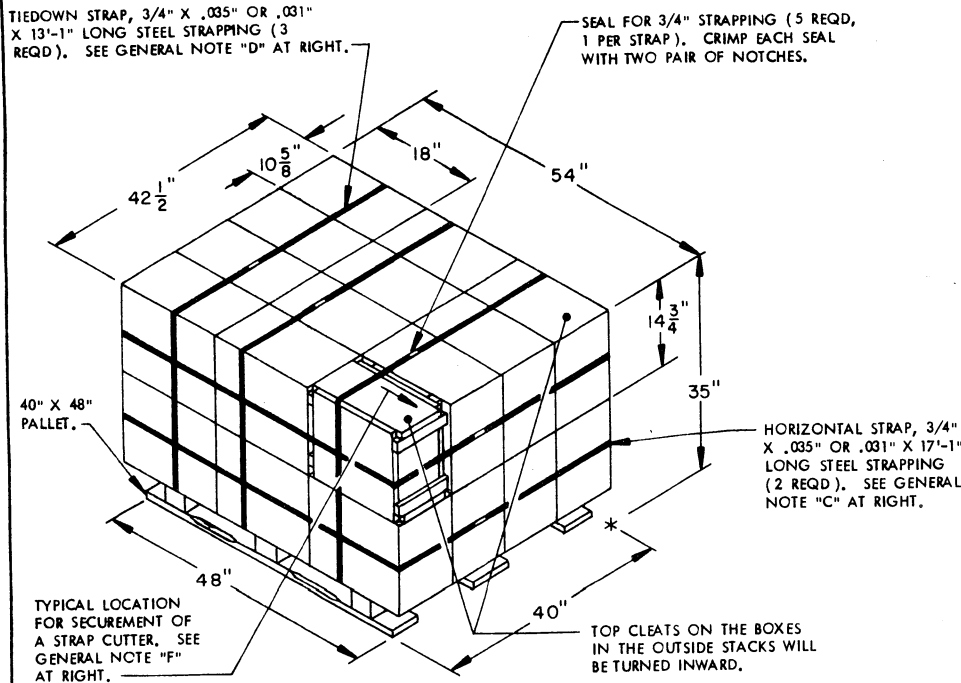

PALLET UNIT B

SEE GENERAL NOTE "B" AT RIGHT.

24 BOXES OF FUZES (300 PER BOX) @ 83 LBS	-----	1,992 LBS (APPROX)
DUNNAGE	-----	6 LBS
PALLET	-----	80 LBS
TOTAL WEIGHT	-----	2,078 LBS (APPROX)
CUBE	-----	46.5 CU FT (APPROX)

BILL OF MATERIAL (UNIT B)

PALLET, 40" X 48"	-----	1 REQD	-----	80 LBS
STEEL STRAPPING, 3/4"	-----	73.42' REQD	-----	5.24 LBS
SEAL FOR 3/4" STRAPPING	-----	5 REQD	-----	NIL

