

# APPENDIX I

## UNITIZATION PROCEDURES FOR BOXED AMMUNITION AND COMPONENTS ON 4-WAY ENTRY PALLETS

CARTRIDGE, 10 GAGE, BLANK, PACKED 500 PER WOODEN  
BOX, UNITIZED 40 BOXES PER 35" X 45 $\frac{1}{2}$ " PALLET;  
APPROX BOX SIZE 15 $\frac{7}{8}$ " L X 9 $\frac{5}{8}$ " W X 9 $\frac{3}{8}$ " H

PALLET UNIT DATA						
ITEMS INCLUDED		HAZARD CLASSIFICATION				WEIGHT (LBS)
NSN	DODIC	DOT CLASS	CG CLASS	QD CLASS	COMP GROUP	
1305-00- 028-5085	A010	C	I	1.4	S	1,552

**NOTICE:** THIS APPENDIX CANNOT STAND ALONE BUT MUST  
BE USED IN CONJUNCTION WITH THE BASIC UNITIZATION  
PROCEDURES DRAWING 19-48-4116-20PA1002.

REVISIONS				DRAFTSMAN GOS/mek	FIELD ENG MMW/ELW
				CHECKER JRW	COP ENGINE OFFICE JRW
				APPROVED, U. S. ARMY ARMAMENT MATERIEL READINESS COMMAND	
				DRAWN - EAD Lawrence Kuster	DORAR - TRG Donald C. Feltus
				APPROVED BY ORDER OF COMMANDING GENERAL, U. S. ARMY MATERIEL DEVELOPMENT AND READINESS COMMAND (DARCOM)	
				John S. Soyad U. S. ARMY DEFENSE AMMUNITION CENTER AND SCHOOL	
<b>U. S. ARMY DARCOM DRAWING</b>					
<b>APRIL 1980</b>					
CLASS	DIVISION	DRAWING	FILE		
19	48	4116/1	20PA 1002		

**DO NOT SCALE**

HORIZONTAL STRAP, 3/4" X .035" OR .031" X 15'-4" LONG STEEL STRAPPING (2 REQD). SEE GENERAL NOTE "C" AT RIGHT.

TIEDOWN STRAP, 3/4" X .035" OR .031" X 12'-8" LONG STEEL STRAPPING (5 REQD). SEE GENERAL NOTE "D" AT RIGHT.

TOP CLEATS ON THE BOXES IN THE OUTSIDE STACKS WILL BE TURNED INWARD.

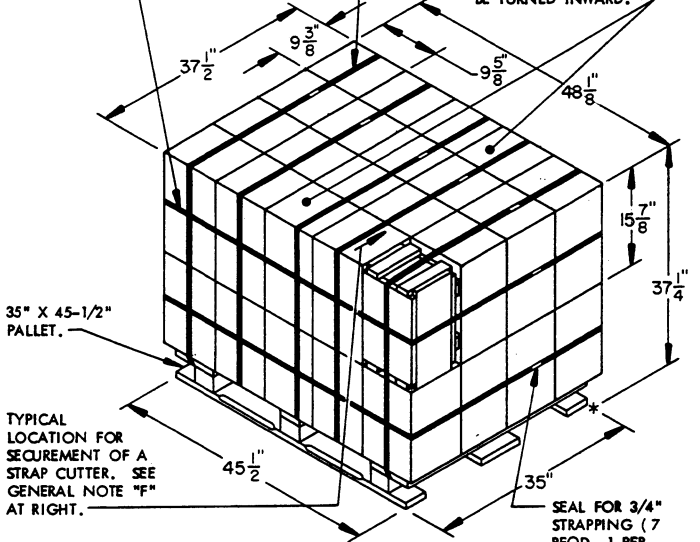

**PALLET UNIT**

SEE GENERAL NOTE "B" AT RIGHT.

40 BOXES OF 10 GAGE CARTRIDGE (500 PER BOX) @ 37 LBS --- 1,480 LBS (APPROX)  
 DUNNAGE ----- 7 LBS  
 PALLET ----- 65 LBS

TOTAL WEIGHT ----- 1,552 LBS (APPROX)

CUBE ----- 38.9 CU FT (APPROX)

**BILL OF MATERIAL**

PALLET, 35" X 45-1/2"	1 REQD	-----	65 LBS
STEEL STRAPPING, 3/4"	94.00' REQD	-----	6.71 LBS
SEAL FOR 3/4" STRAPPING	7 REQD	-----	NIL

**GENERAL NOTES**

- A. THIS APPENDIX CANNOT STAND ALONE BUT MUST BE USED IN CONJUNCTION WITH THE BASIC UNITIZATION PROCEDURES DRAWING 19-48-4116-20PA1002. TO PRODUCE AN APPROVED UNIT LOAD, ALL PERTINENT PROCEDURES, SPECIFICATIONS AND CRITERIA SET FORTH WITHIN THE BASIC DRAWING WILL APPLY TO THE PROCEDURES DELINEATED IN THIS APPENDIX. ANY EXCEPTIONS TO THE BASIC PROCEDURES ARE SPECIFIED IN THIS APPENDIX.
- B. DIMENSIONS, CUBE AND WEIGHT OF A PALLET UNIT WILL VARY SLIGHTLY DEPENDING UPON THE ACTUAL DIMENSIONS OF THE BOXES AND THE WEIGHT OF THE SPECIFIC ITEM BEING UNITIZED.
- C. INSTALL EACH HORIZONTAL STRAP TO ENCIRCLE EACH LAYER OF BOXES ON THE PALLET. HORIZONTAL STRAP MUST BE TENSIONED AND SEALED PRIOR TO APPLICATION OF TIEDOWN STRAPS.
- D. INSTALL EACH TIEDOWN STRAP TO PASS UNDER THE DECK/STRINGER BOARDS OF THE PALLET AND TO BE LOCATED BETWEEN THE VERTICAL END CLEATS OF THE BOXES. TIEDOWN STRAPS WILL NOT BE APPLIED UNTIL THE HORIZONTAL STRAPS HAVE BEEN TENSIONED AND SEALED.
- E. THE FOLLOWING DARCOM DRAWINGS ARE APPLICABLE FOR OUTLOADING AND STORAGE OF THE ITEMS COVERED BY THIS APPENDIX.
  - CARLOADING ----- DRAWING 19-48-4115-5PA1002
  - TRUCKLOADING ----- DRAWING 19-48-4117-11PA1003
  - STORAGE ----- DRAWING 19-48-4118-1-2-14-22PA1002
- F. FOR METHOD OF SECURING A STRAP CUTTER TO THE PALLET UNIT, SEE DARCOM DRAWING 19-48-4127-20P1000.
- G. IF ITEMS COVERED HEREIN ARE UNITIZED PRIOR TO ISSUANCE OF THIS APPENDIX, THE BOXES NEED NOT BE REUNITIZED SOLELY TO CONFORM TO THIS APPENDIX.
- H. THE UNITIZATION PROCEDURES DEPICTED HEREIN MAY ALSO BE USED FOR UNITIZING 10 GAGE CARTRIDGES WHEN IDENTIFIED BY DIFFERENT NATIONAL STOCK NUMBERS (NSN) THAN WHAT IS SHOWN ON THE TITLE PAGE, PROVIDED THE BOX PACK DOES NOT VARY FROM WHAT IS DELINEATED HEREIN. THE EXPLOSIVE CLASSIFICATION OF OTHER ITEMS MAY BE DIFFERENT THAN WHAT IS SHOWN.

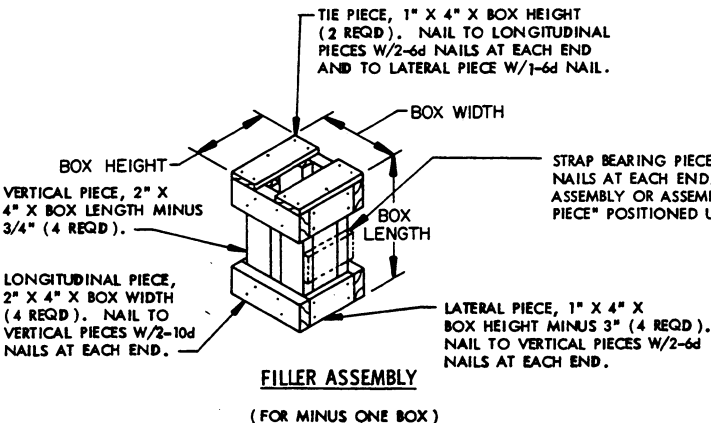

**FILLER ASSEMBLY**

(FOR MINUS ONE BOX)